

# SEM1

*Multi-function single phase meter*



- Multi-parameter measurements
- Accuracy Class 1 active energy
- Wi-Fi available (SEM1-WL only)
- RS485 Modbus RTU
- Bi-directional measurement
- Easy connection solution
- Compact design

**User Manual**  
**V1.04**

## Statements

All rights reserved. Without the written permission of the company, no paragraphs or chapters in this manual can be extracted, copied or reproduced in any form. Otherwise, the violator shall bear all consequences.

Eastron reserves all legal rights.

Eastron reserves the right to amend the product specifications in this manual without prior notice. Before placing an order, please contact our company or local agent to get the latest specifications.

# CONTENT

- Version History ..... 1
- Risk Information ..... 2
- Chapter 1. Introduction ..... 4
  - 1.1 Product Introduction ..... 4
  - 1.2 CT Disconnection Detection Function ..... 4
- Chapter 2. Technical Parameters ..... 5
  - 2.1 Specifications ..... 5
  - 2.2 Marking ..... 8
  - 2.3 Dimensions ..... 8
  - 2.4 Mounting ..... 9
  - 2.5 RJ12 Terminal Definition ..... 10
  - 2.6 Wiring Diagram ..... 10
- Chapter 3. Operation ..... 11
  - 3.1 Operation of Wi-Fi Communication ..... 11
  - 3.2 Definition of button and LEDs ..... 15
  - 3.3 Maintenance ..... 15

## Version History

Version	Date	Changes
1.00	2025-4-15	Initial issue
1.01	2025-8-7	Add information about SEM1-M/WL
1.02	2025-10-15	Add information about operating Wi-Fi Communication Optimize some words and sentences
1.03	2026-04-28	Add Chapter CT Disconnection Detection Function
1.04	2026-06-16	Revise the description in Section 1.2 CT Disconnection Detection Function. 1.1 Product Introduction: SEM3 revised to SEM1. Change the laser drawing and Dimension drawing

## Risk Information

### Information for Your Own Safety

This manual does not contain all of the safety measures operating the equipment (module, device) for different conditions and requirements. However, it does contain information which you must know for your own safety and to avoid damages. This information is highlighted by a warning triangle, which indicates the degree of potential danger.



#### Warning

This means that failure to observe the instruction can result in death, serious injury or considerable material damage.



#### Caution

This means hazard of electric shock and failure to take the necessary safety precautions will result in death, serious injury or considerable material damage.

### Qualified personnel

Operation of the equipment (module, device) described in this manual must only be performed by qualified personnel. Qualified personnel in this manual means people who are authorized to commission, start up, ground and label devices, systems and circuits in accordance with Safety Regulatory standards.

### Proper handling

The prerequisites for perfect, reliable operation of the product are proper transport, storage, installation and operation and maintenance. When operating electrical equipment, some parts of this equipment automatically carry dangerous voltages. Improper handling can therefore result in serious injuries or material damages.

- ✧ Use only insulating tools.
- ✧ Do not connect while circuit is live (hot).
- ✧ Place the meter only in dry surroundings.
- ✧ Do not mount the meter in an explosive area or expose the meter to dust, mildew and insects.
- ✧ Make sure the wires are suitable for the maximum current of this meter.
- ✧ Make sure the AC wires are connected correctly before activating the current/voltage to the meter.
- ✧ Do not touch the clamps directly with metal, blank wire or your bare hands as you may get electrical shock.
- ✧ Make sure the protection cover is placed after installation.
- ✧ Installation, maintenance and reparation should only be done by qualified personnel.
- ✧ Never break the seals or open the front cover as this might influence the function, and will void the warranty.
- ✧ Do not drop, or allow strong physical Hit on the meter as the high precisely components inside may be damaged.
- ✧ This product is designed to be mounted inside of switchboards or cabinet on DIN rail.
- ✧ This device must have a suitable sized Circuit Breaker feeding the Multi Function Energy Meter so it does

not exceed the maximum rated current.

- ✧ The supply wiring of this device shall be suitable sized cable to match the installed circuit breaker.
- ✧ A Disconnection Device (Circuit Breaker) should be installed close to the Multi Function Energy Meter.
- ✧ The Disconnection Device shall be marked as the Disconnection Device for the Multi Function Energy Meter.

#### **Disclaimer**

We have checked the contents of this publication and every effort has been made to ensure that the descriptions are as accurate as possible.

However, deviations from the description cannot be completely ruled out, so that no liability can be accepted for any errors contained in the information given. The data in this manual is checked regularly and the necessary corrections are included in subsequent editions. We are grateful for any improvements that you suggest.

## Chapter 1. Introduction

### 1.1 Product Introduction

Eastron SEM1 Series is a new generation din rail mounted energy meter, equipped with Wi-Fi and RS485 connectivity. With multi parameters measurement, SEM1 can be used for energy monitoring of various applications, such as PV energy management, smart building, industrial equipment, etc.

Eastron SEM1 measures characteristics of 1P2W network, including voltage, frequency, current, power, active and reactive energy, imported or exported, power factor etc. Energy is measured in kWh and kVArh.

Eastron SEM1 is designed in compact size. To save installation and maintenance cost, all terminals of SEM1 adopt spring terminals or RJ terminals for easy connection.

The measurement mode of SEM1 is total mode. In total mode, import and export energy will be measured separately. Total energy equals to import energy plus export energy.

### 1.2 CT Disconnection Detection Function

This instrument features a current transformer (CT) disconnection detection function, which monitors the integrity of the CT circuit in real time and promptly identifies metering circuit anomalies.

Detectable State:

- CT open circuit (disconnection): The CT secondary side is not properly connected to the instrument. This includes initial non-connection, cable break, or loose terminal during operation.

Alarm Methods:

When a CT disconnection is detected, the instrument alerts via the following methods:

Alarm Method	Description
Indicator lights (light code)	When CT disconnection occurs, all LED indicators remain steadily lit.
Communication protocol	A disconnection status register is provided via the communication interface (Modbus RTU). The master station can read this register to obtain the current CT status.

Disconnection Information Querying:

- Active reporting: Not supported. The instrument does not actively push disconnection events to the platform.
- Platform query: The master station (platform) can read the CT disconnection status register by sending a Modbus query message to check whether a disconnection has occurred.

## Chapter 2. Technical Parameters

### 2.1 Specifications

Table 1

Electrical Characteristics		
Measurement Accuracy	Voltage	± 0.5%
	Current	± 0.5% (4A to 120A)
		± 1% (1A to 4A)
		± 3% (0.06A to 1A)
	Frequency	± 0.2%
	Power Factor	± 0.01
	Active Power	± 1% IEC 61557-12 Class 1
	Reactive Power	± 1% IEC 61557-12 Class 1
	Apparent Power	± 1% IEC 61557-12 Class 1
Active Energy	± 1% IEC 62053-21 Class 1	
Reactive Energy	± 2% IEC 62053-23 Class 2	
Data Update Rate	Active Power: 50mS(RS485), 100mS(Wi-Fi)	
Input-Voltage	Un	230V
	Working Voltage Range	100 to 277 V ac L-N
	Frequency Range	50/60Hz
Mechanical Characteristics		
Net Weight	≈61g (SEM1)	
IP Degree of Protection (IEC 60529)	IP51 Front Display IP20 Whole Meter	
Dimensions (DxHxW)	68.5*94*19mm	
Mounting	DIN Rail 35mm	
Material of Meter Case	Self-extinguishing UL 94 V-0	
Mechanical Environment	M1	
Environmental Characteristics		
Operating Temperature	-40 °C to +70°C	
Storage Temperature	-40 °C to +85°C	
Operation humidity	≤90% Non-condensing	
Storage humidity	≤95% Non-condensing	
Pollution Degree	2	
Altitude	Up to 2000m	
Vibration	10Hz to 150Hz, IEC 60068-2-6	
Electromagnetic Compatibility		
Electrostatic Discharge	IEC 61000-4-2	
Immunity to Radiated Fields	IEC 61000-4-3	
Immunity to Fast Transients	IEC 61000-4-4	
Surge (Impulse) Immunity	IEC 61000-4-5	
Conducted Immunity	IEC 61000-4-6	
Immunity to Magnetic Fields	IEC 61000-4-8	
Immunity to Voltage Dips	IEC 61000-4-11	
Radiated Emissions	CISPR 32	
Conducted Emissions	CISPR 32	
Safety		
Measurement Category	Per IEC61010-1 CAT III	
Current Inputs	Require External Current Transformer for Insulation	
Over-voltage Category	CAT III	
Protective Class	II	
Communications		

Interface 1	RS485 Port
Interface 1 Protocol	MODBUS RTU
Communication Address	1 to 247
Transmission Mode	Half Duplex
Data Type	Floating Point
Transmission Distance	1000m Maximum
Transmission Speed	2400/4800/9600(Default)/19200/38400/115200bps
Parity	NONE(Default)/ ODD / EVEN
Stop Bits	1 or 2
Response Time	<50 ms
Interface 2	Wi-Fi
Interface 2 Protocol	MODBUS TCP
Data Type	Floating Point
RF Band	2.4 GHz to 2.5 GHz
Max. RF Power	<20 dBm
Wi-Fi Protocol	802.11 b/g/n
Wi-Fi Range	Up to 30m / 100ft indoors and 50m / 160ft outdoors (Depends on local conditions)

Table 2

Note: ● = included  
— = excluded

Features	Models	
	SEM1-WL (-2)	SEM1-M (-2)
<b>Instantaneous Measurements</b>		
Current	●	●
Voltage L-N	●	●
Voltage L-L	—	—
Frequency	●	●
Active Power	●	●
Reactive Power	●	●
Apparent Power	●	●
Power Factor	●	●
<b>Energy Values</b>		
Active Energy	●	●
Reactive Energy	●	●
Apparent Energy	—	—
<b>Network</b>		
1 Phase 2 Wires	●	●
2 Phase 3 Wires	—	—
3 Phase 3 Wires	—	—
3 Phase 4 Wires	—	—
CT Programmable	●	●
PT Programmable	—	—
<b>Inputs and Outputs</b>		
Alarms	—	—
<b>Communications</b>		
RS485	●	●

Wi-Fi	•	—
-------	---	---

Table 3

Model	Communication	Terminal (AC)
SEM1-WL	RS485+WiFi (Internal antenna)	Spring type
SEM1-WL-2	RS485+WiFi (External antenna)	Plug-in type
SEM1-M	RS485	Spring type
SEM1-M-2	RS485	Plug-in type

**Technical Standards:**

- [1] EN IEC61326-1: 2021 Electromagnetic Compatibility Directive - Electrical equipment for measurement, control and laboratory use - EMC requirements - Part 1: General requirements
- [2] EN IEC 61326-2-3: 2021 Electromagnetic Compatibility Directive
- [3] EN61010-1:2010+A1:2019 Low Voltage Directive 2014/35/EU - Safety requirements for electrical equipment for measurement, control, and laboratory use - Part 1: General requirements
- [4] EN61010-2-030:2010 Low Voltage Directive 2014/35/EU - Particular requirements for testing and measuring circuits
- [5] EN 50470-3:2022 Electricity metering equipment - Part 3: Particular requirements - Static meters for AC active energy (class indexes A, B and C)
- [6] EN IEC62053-21: 2021 Electricity metering equipment - Particular requirements - Part 21: Static meters for AC active energy (classes 0, 5, 1 and 2)

## 2.2 Marking

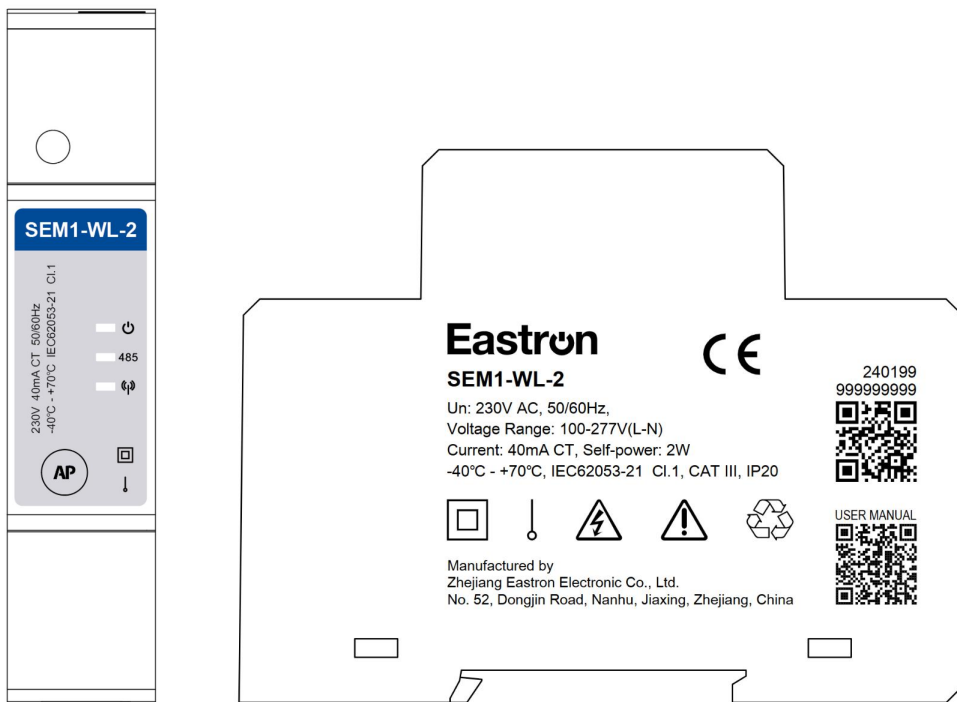

(SEM1-WL-2 nameplate and laser printing)

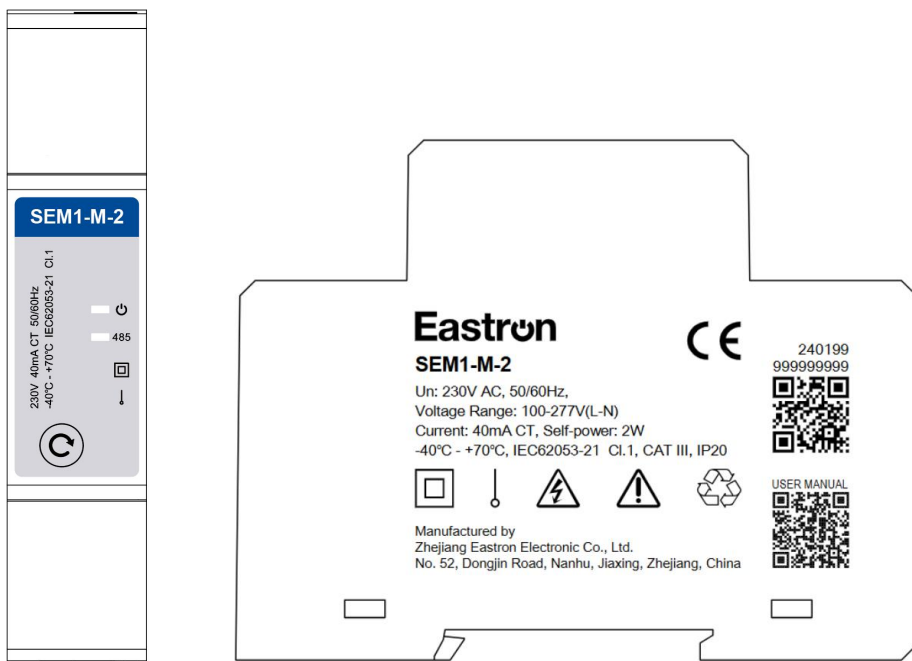

(SEM1-M-2 nameplate and laser printing)

## 2.3 Dimensions

SEM1-M/WL	SEM1-M/WL-2
-----------	-------------

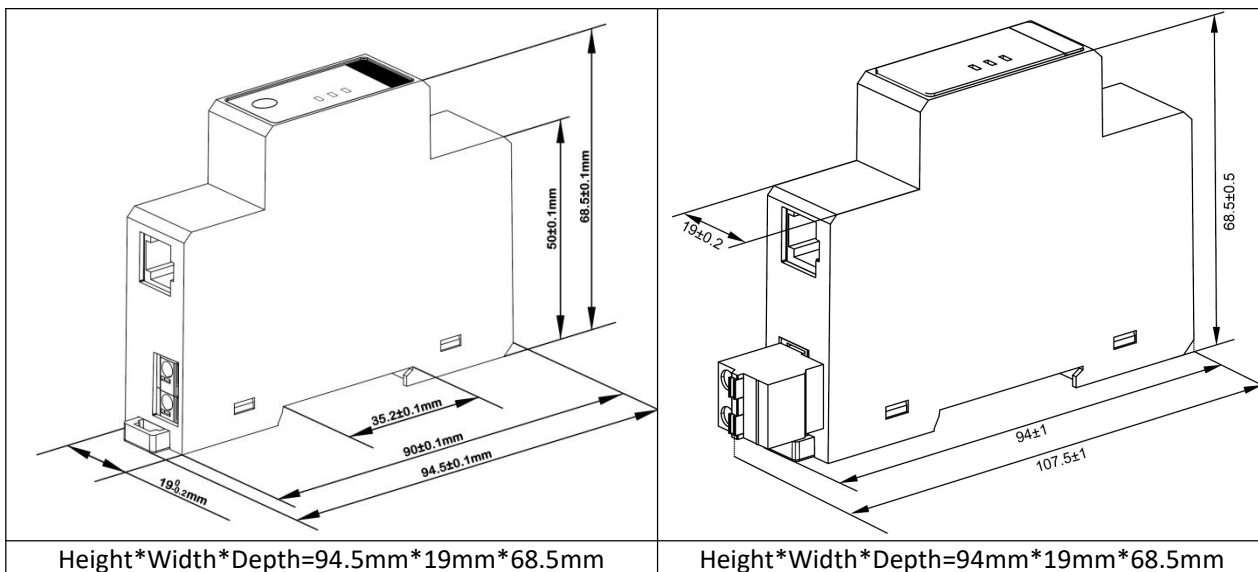

## 2.4 Mounting

- Step 1: Select a 35mm-wide DIN rail, Pull down the back-end clip on the meter to unlock the mounting mechanism.
- Step 2: Align Upper Slot with DIN Rail. Position the upper slot of the meter's DIN rail groove onto the DIN rail, ensuring full contact (see Figure 1).
- Step 3: Following the direction indicated in Figure 1, engage the lower slot of the DIN rail groove onto the DIN rail until audibly seated (see Figure 2).
- Step 4: Push up the back-end clip to lock the meter firmly onto the DIN rail (see Figure 3).

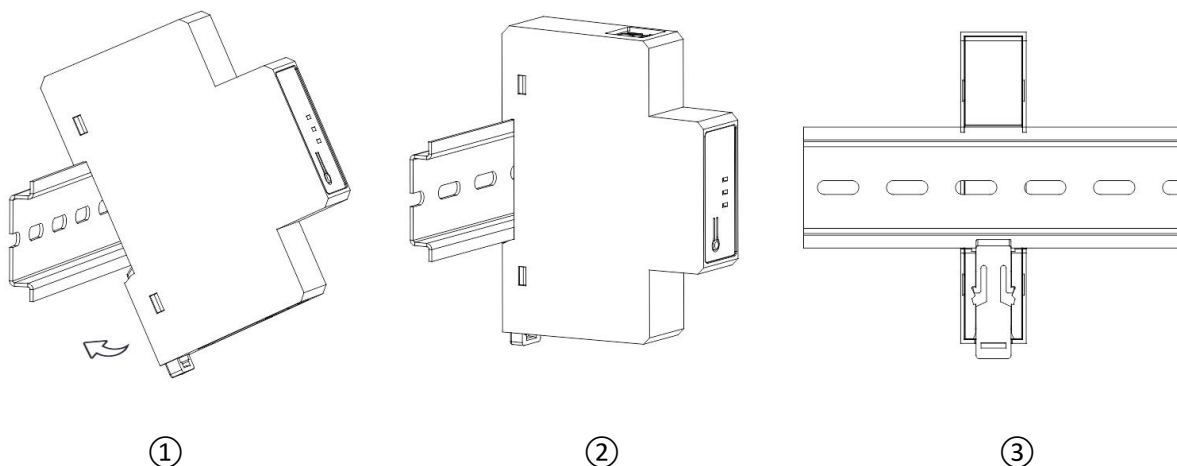

## 2.5 RJ12 Terminal Definition

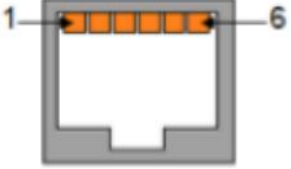
Interface	Colour-definition
	1.Brown: I+
	2.White: I-
	3.Black: None
	4.Orange: None
	5.Red: None
	6.Yellow: None

## 2.6 Wiring Diagram

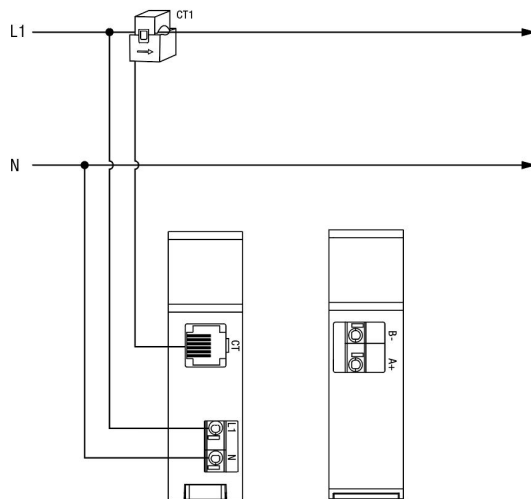

## Chapter 3. Operation

### 3.1 Operation of Wi-Fi Communication

SEM1-WL(-2) comes with built-in Wi-Fi functionality. When it is powered on, the three LEDs on the front panel will flash and self-check program will start. If everything is normal, the Wi-Fi indicator will light up blue, and the meter will enter AP mode, with the AP name formatted as "EM-serial number".

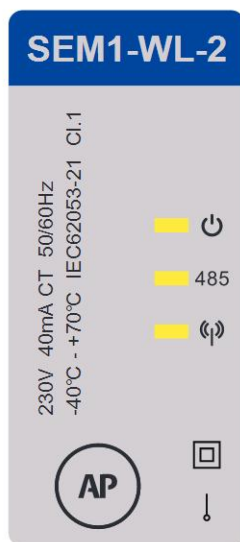

User can search all available Wi-Fi AP by PC or Phone, in which the AP of the meter is listed. For example:



Double click the AP of the meter "EM-240460817", and enter the password to build the connection. Default password is the same as serial number, i.e. 240460817.

After a successful connection, the user can access the meter's built-in web server by entering 192.168.4.1 in a web browser.

The web-server including 3 pages: Data Sync, Setting and OTA (Over-The-Air Technology).

Data Sync: The data will be read instantaneously.

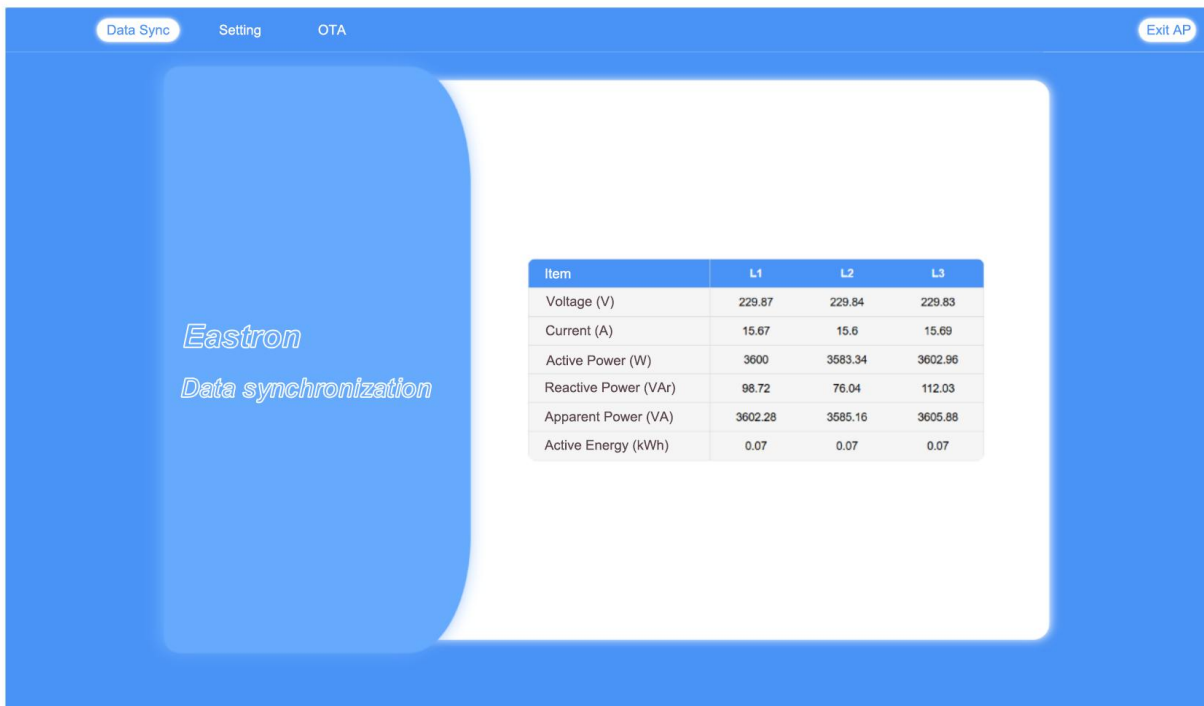

Setting: set up Wi-Fi of the energy meter in AP mode and in station mode.

After a successful connection, the user can configure the meter to station mode and connect it to another available Wi-Fi network. The specific steps are as follows:

1. Set Mode to Station: On the settings interface, select "Station" as the operating mode.
2. Select Network: Choose your desired Wi-Fi network from the available list.
3. Enter Password: Input the password of the selected network to establish the connection.

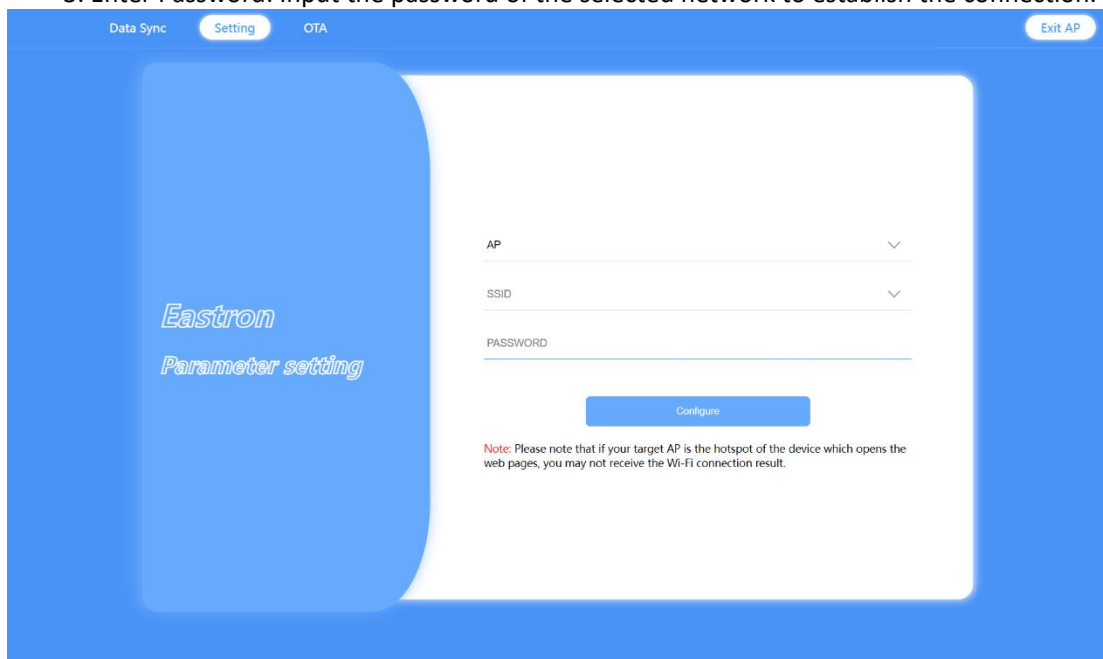

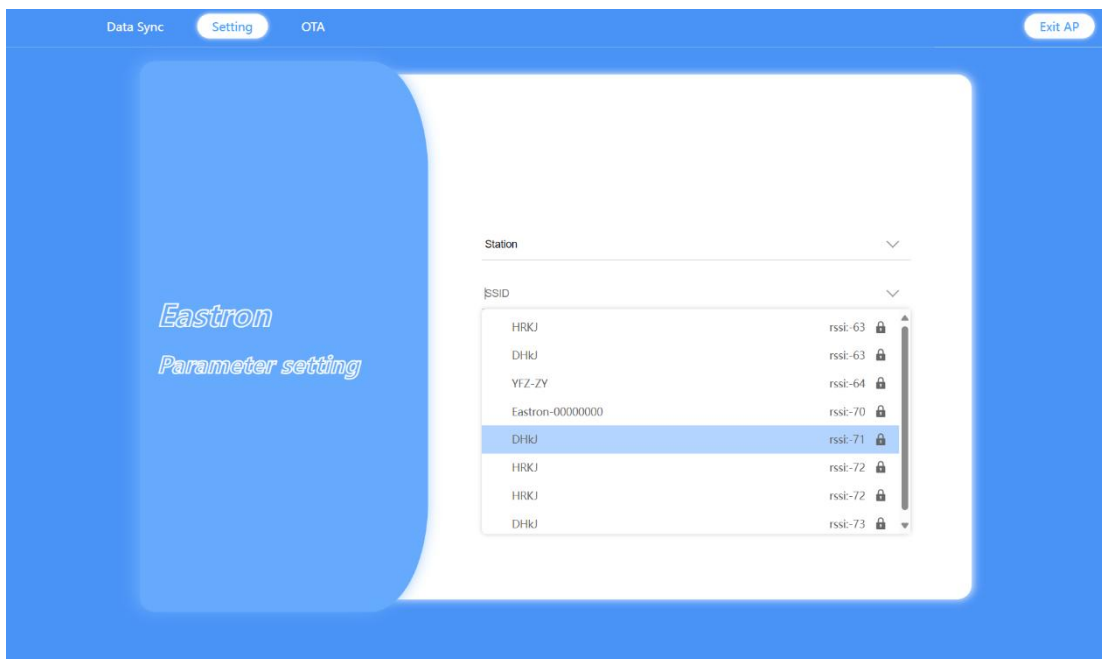

**Wi-Fi Connection Status Indicator**

During the connection process, the Wi-Fi LED on the meter's front panel will flash continuously. A successful connection is indicated when the LED stops flashing and remains steadily lit.

**Retrieving Meter Information Using MDNS**

The user can use MDNS (Multicast DNS) to retrieve the meter's information, including its IP address, Serial Number (SN), MAC address, and model. If multiple meters are on the same network, MDNS will list the information for all of them.

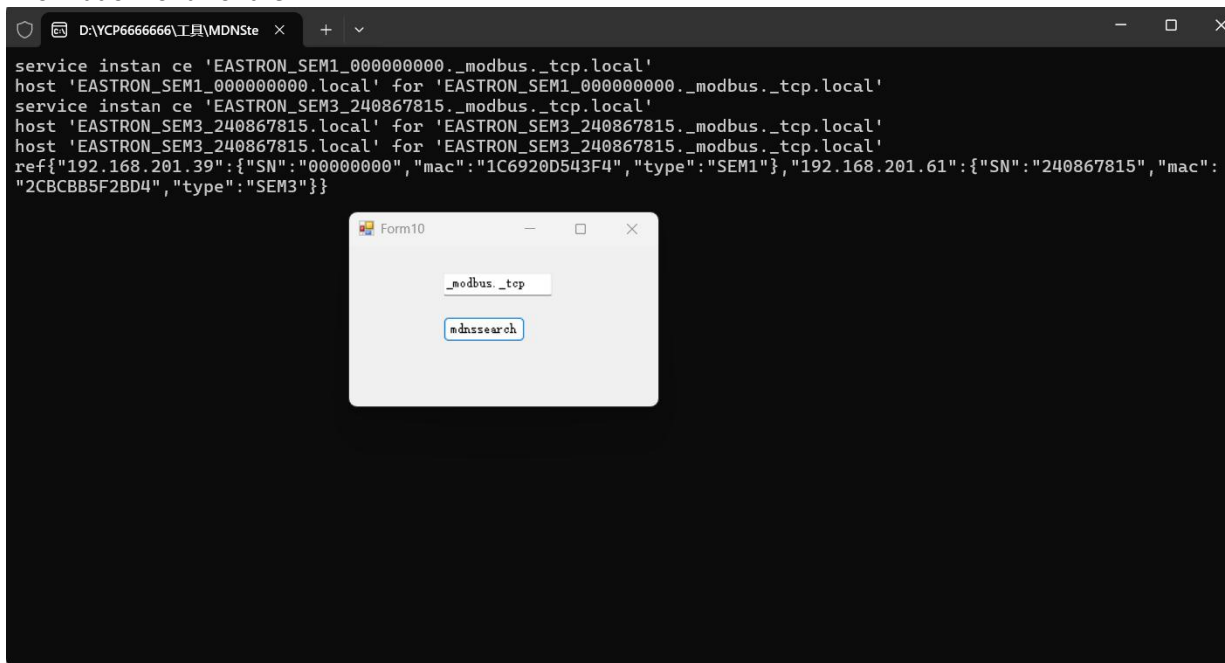

OTA: update the firmware of the meter over-the-air.

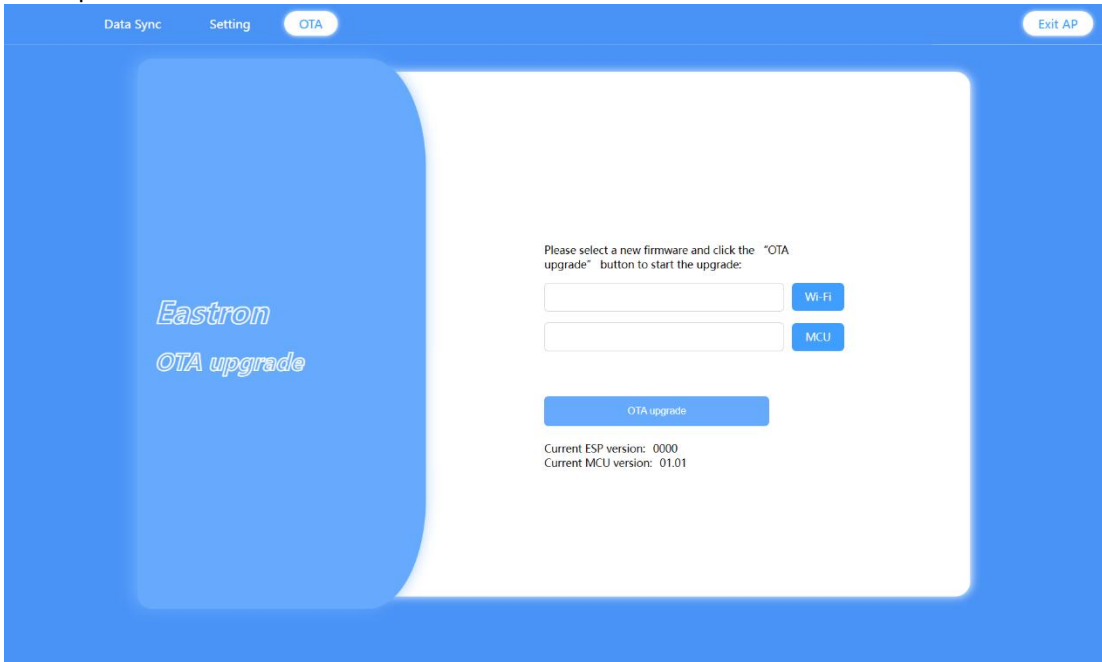

### 3.2 Definition of button and LEDs

Interface	Definition	Introduction
<p>The diagram shows the front panel of the SEM1-WL-2 meter. It features three LEDs: a red power LED (1), a green RS485 LED (2), and a blue Wi-Fi LED (3). Below these is a square AP key (4) with a circle containing 'AP' and a power symbol. Technical specifications on the left include: 230V 40mA CT 50/60Hz, -40°C ~ +70°C, IEC62053-21 Cl.1.</p>	<p>1.Power LED (Red)</p>	<p>1.Stay on: Light up when the meter is powered on with no load. 2.Flashing: Blinks when a load is connected.</p>
	<p>2.RS485 LED (Green)</p>	<p>1.Stay on: During the OTA upgrading. 2.Flashing: Blinks when the meter is communicating normally.</p>
	<p>3.Wi-Fi LED (Blue) (Only for SEM1-WL(-2))</p>	<p>In the AP mode: 1.Stay on: Light up when the meter enters the AP mode. 2.Flashing: Blinks when the meter is disconnected to the network. 3.Off: Light off after the meter is connected to the network.</p> <p>In the station mode: 1.Stay on: Light up when the Wi-Fi module malfunctions. 2.Flashing: Blinks during the meter wireless communicating.</p>
	<p>4.AP Key</p>	<p>Press and hold for 3 seconds to enter/exit AP mode (Only for SEM1-WL(-2)). Press and hold for 10 seconds to reset communication parameters.</p>

**\*Major Fault Alarm:**

When all LED indicators on the instrument panel remain steadily lit, perform the following checks:

1. CT disconnection

The current transformer (CT) circuit is not properly completed. Typical conditions include:

- CT not connected: The CT secondary side is not connected to the instrument or is completely open-circuited.
- CT disconnection fault: Broken connecting cable, loose terminal, or poor contact.

**\*Parameter initialization:**

when initializing communication recovery by holding the button, all the lights stay on for 3 seconds as a prompt and then turn off.

### 3.3 Maintenance

Under normal operating conditions, electricity meters require only minimal maintenance. Depending on the actual working conditions, the power supply should be cut off before conducting equipment inspections and removing accumulated dust or foreign objects. It is necessary to regularly check the corrosion status of all connection terminals, which is particularly important in vibrating environments.

The front of the case should be wiped with a dry cloth only. Use minimal pressure, especially over the viewing window area. If necessary, wipe the case with a dry cloth. Water should not be used. If the case exterior or terminals should be contaminated accidentally with water, the unit must be thoroughly dried before further use. If there is any water ingress, factory inspection and refurbishment is recommended.

If the product requires repair, please kindly send it back to Eastron or Eastron's distributor.

