

## Datasheet

- Three phase 1/5A current transformer operated
- MID B+D certified
- Bi-directional measurement IMP & EXP
- Modbus TCP/IP Communication
- Multi-parameters measurement
- Plug-in solution
- LCD with white backlight, adjustable backlit time

SDM630MCT-TCP is a new multi-function energy meter designed by EASTRON. The meter can work with 1p2w, 3p3w, 3p4w electricity grid. It provides all important electrical parameters: voltage, current, power, PF, THD, frequency, demand, energy etc. In order to measure energy, the unit requires voltage and current inputs in addition to the supply required to power the product. The requisite current input(s) are obtained via current transformers(CT). Certified in the UK according to EU directive 2014/32/EU. MID certificate number 0120/SGSO703.

The meter SDM630MCT-TCP is equipped with a Ethernet communication port and MODBUS-TCP protocol is adopted for remote reading and programming. The meter has a big back-lighted LCD showing data and uses 4 touch keypads in front for data checking and programming.



## Specification Table

Specification	
Nominal voltage(Un)	3x230/400 V ac
Voltage range	100-276V L-N, Max. 276V / 172-480V L-L, Max. 480V
AC voltage withstand	4KV for 1 minute
Impulse voltage withstand	6KV-1.2μS
Rated current (Ib)	1A/5A CT
Operational current range	0.4% Ib-I <sub>max</sub>
Over current withstand	20 I <sub>max</sub> for 0.5s
Operational frequency range	50 or 60Hz
Power consumption per phase	≤ 2W/10VA
Display	LCD
Max reading	9999999.9 kWh/kVarh

Performance criteria	
Operating humidity	≤ 90%, no condensing
Storage humidity	≤ 95%, no condensing
Operating temperature	-40°C - +70°C
Storage temperature	-40°C - +80°C
Reference temperature	23°C± 2°C
International standard	IEC 62052-11:2021/A11:2022 / EN50470-3:2022
Accuracy class	Class 0.5S / Class C
Installation category	CAT III
Mechanical environment	M1
Electromagnetic environment	E2
Degree of pollution	2
Protection against penetration of dust and water	IP51 front panel, IP20 whole meter
Insulating encased meter of protective class	II
Electrostatic discharges	8kV contact / 15kV air gap
Radiated & conducted emissions	EN 55022

Accuracy	
Voltage, Current	±0.5%
Frequency	±0.2%
Power factor	±0.01
Active power , Apparent power	±1%
Reactive power	±1%
Reactive energy(Varh)	Class 2 IEC 62053-23
Active energy (Wh)	Class 0.5S IEC62053-22 / Class C EN50470-3:2022

Ethernet Communication	
Interface Standard and Protocol	Ethernet Modbus TCP
Communication Address	1~247
IP Address Assignment	DHCP Factory default address: 192.168.1.200
Data Type	Floating Point
Transmission Speed	> 100MB
Response Time	< 100mS

For more information on these products, please contact our sales team on 86 0573 83698881 or email [sales@eastrongroup.com](mailto:sales@eastrongroup.com)

[www.eastrongroup.com](http://www.eastrongroup.com)

### Wiring Configuration

### Dimension Drawing

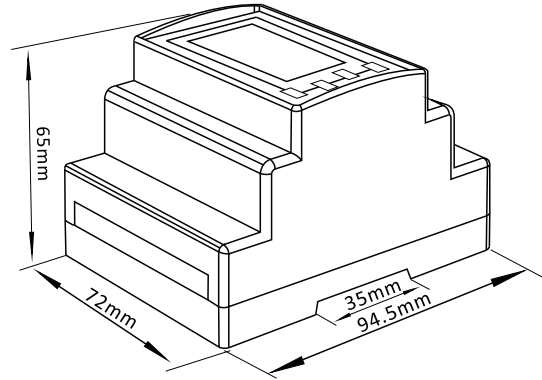
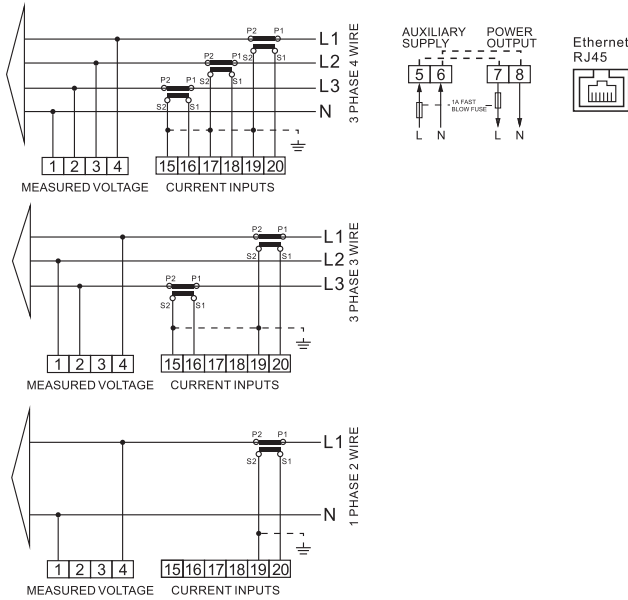

Height 94.5mm  
Width 72mm  
Depth 65mm

### Ordering Options

Meter Type	Description of Meter
SDM630MCT-TCP	3PH-4W, 3PH-3W, 1PH-2W, 3x230(400)V, 1A or 5A CT input, Class 1.0, 50/60Hz, backlit LCD display, Modbus-TCP output. Measures kWh, kVarh, W, Var, VA, V, A, PF, THD, Hz, Max.DMD, Imp_kWh, Exp_kWh etc.

### Conformity References

**Measurement category:** IEC 61010-1 CAT III

**Over-voltage category:** CAT III

**Dielectric withstand:** IEC 61010-1 double insulated, IEC 62052-31:2015

**Protective class:** II

**EMC:** EN 61326-1:2021 & EN 61326-2-3:2021, EN IEC 62052-11:2021/A11:2022

**Low Voltage Directive:** EN 61010-1:2010+A1:2019 & EN IEC 61010-2-030:2021+A11:2021, IEC 62052-31:2015

**MID Std:** EN 50470-3:2022 and IEC / EN IEC 62052-11:2021/A11:2022, IEC 62052-31:2015

**UL Std:** UL 61010-1, UL 61010-2-030