

# SDM230-Lora

## *Smart Single Phase Energy Meter*



## **USER MANUAL**

### **2026 V1.2**

# Statements

All rights reserved. Without the written permission of the company, no paragraphs or chapters in this manual can be extracted, copied or reproduced in any form. Otherwise, the violator shall bear all consequences.

Eastron reserves all legal rights.

Eastron reserves the right to amend the product specifications in this manual without prior notice. Before placing an order, please contact our company or local agent to get the latest specifications.

# CONTENTS

Version History .....	1
Risk Information .....	2
Chapter 1. Introduction .....	4
1.1 Product Introduction .....	4
1.2 Product Characteristics .....	4
1.3 Application Scenarios .....	4
1.4 Pulse Output .....	5
Chapter 2. Technical Parameters .....	6
2.1 Specifications .....	6
2.2 Dimensions .....	9
2.3 Mounting .....	9
2.4 Wiring Diagram .....	10
Chapter 3. Operation .....	11
3.1 Button Function .....	11
3.2 Installation Display .....	11
3.3 Basic information display .....	12
3.4 Auxiliary information display .....	16
3.5 LoRa Setting .....	17
3.6 Setup Mode 1 .....	17
3.7 Setup Mode 2 .....	21
Chapter 4. LoRaWAN .....	24
4.1 LoRaWAN Classes .....	24
4.2 Active Upload Mode .....	24
4.3 Join .....	24
4.4 Join Delay .....	24
4.5 Communication .....	24
Chapter 5. Declaration of Conformity ( For MID meter only) .....	27

## Version History

Version	Date	Changes
1.0	2025-6-17	Initial issue
1.1	2026-3-24	Update to the new standard version
1.2	2026-4-21	Change product images

## Risk Information

### Information for Your Own Safety

This manual does not contain all of the safety measures operating the equipment (module, device) for different conditions and requirements. However, it does contain information which you must know for your own safety and to avoid damages. This information are highlighted by a warning triangle indicating the degree of potential danger.

---



#### Warning

This means that failure to observe the instruction can result in death, serious injury or considerable material damage.



#### Caution

This means hazard of electric shock and failure to take the necessary safety precautions will result in death, serious injury or considerable material damage.

### Qualified personnel

Operation of the equipment (module, device) described in this manual may only be performed by qualified personnel. Qualified personnel in this manual means person who are authorized to commission, start up, ground and label devices, systems and circuits according to safety and Regulatory standards.

### Proper handling

The prerequisites for perfect, reliable operation of the product are proper transport, proper storage, installation and proper operation and maintenance. When operating electrical equipment, parts of this equipment automatically carry dangerous voltages. Improper handling can therefore result in serious injuries or material damage.

- ✧ Use only insulating tools.
- ✧ Do not connect while circuit is live (hot).
- ✧ Place the meter only in dry surroundings.
- ✧ Do not mount the meter in an explosive area or expose the meter to dust, mildew and insects.
- ✧ Make sure the wires are suitable for the maximum current of this meter.
- ✧ Make sure the AC wires are connected correctly before activating the current/voltage to the meter.
- ✧ Do not touch the meter connecting clamps directly with metal, blank wire and your bare hands as you may get electrical shock.
- ✧ Make sure the protection cover is placed after installation.
- ✧ Installation, maintenance and reparation should only be done by qualified personnel.
- ✧ Never break the seals and open the front cover as this might influence the function of the meter, and will cause no warranty.
- ✧ Do not drop, or allow strong physical impact on the meter as the high precisely components inside may be damaged.
- ✧ Designed to be mounted inside of switchboards or cabinet on DIN rail.

- ✧ This device must have a suitable sized Circuit Breaker feeding the Multi Function Energy Meter so it does not exceed the maximum rated current.
- ✧ The supply wiring of this device shall be suitable sized cable to match the installed circuit breaker.
- ✧ A Disconnection Device (Circuit Breaker) should be installed close to the Multi Function Energy Meter.
- ✧ The Disconnection Device shall be marked as the Disconnection Device for the Multi Function Energy Meter.

**Disclaimer**

We have checked the contents of this publication and every effort has been made to ensure that the descriptions are as accurate as possible.

However, deviations from the description cannot be completely ruled out, so that no liability can be accepted for any errors contained in the information given. The data in this manual is checked regularly and the necessary corrections are included in subsequent editions. We are grateful for any improvements that you suggest.

## Chapter 1. Introduction

### 1.1 Product Introduction

SDM230-Lora measures and displays the characteristics of single phase two wire (1p2w), including voltage, frequency, current, power, active and reactive energy, imported or exported. Energy is measured in terms of kWh, kVAh. Maximum demand current can be measured over preset periods of up to 60 minutes.

The meter is Max. 100A direct connected and does not need to connect with external current transformers(CT). LoRa communication is available on the meter for long distance wireless data transmission.

### 1.2 Product Characteristics

- Bi-directional measurement IMP & EXP
- Multi-parameters measurement
- LCD with white backlit, adjustable backlit time
- LoRaWAN communication

#### Measurements:

- Phase voltage: V
- Current: A
- Active power: W
- Reactive power: VAr
- Apparent power: VA
- Frequency: Hz
- Power factor: PF
- Active energy: Ep\_imp (import active energy), Ep\_exp (export active energy), Ep\_total (total active energy)
- Reactive energy: Eq\_imp (import reactive energy), Eq\_exp (export reactive energy), Eq\_total (total reactive energy)
- Maximum demand: MD

#### Setup:

- Demand interval time
- Backlit time
- Clear Max. demand info & resettable energy
- Password modification

### 1.3 Application Scenarios

The SDM230-Lora is a single-phase multi-function energy meter designed for scenarios such as residential complexes, commercial buildings, industrial facilities, and IoT-based energy management platforms. It adopts LoRaWAN wireless communication technology, supporting remote meter reading and data monitoring, aiming to deliver a flexible, efficient, and low-power intelligent power management solution for users.

## 1.4 Pulse Output

The meter is equipped with pulse output, which is fully isolated from the inside circuit. It generates pulses in proportion to the measured energy. The pulse output is polarity dependent, passive transistor output requiring an external voltage source for correct operation. For this external voltage source, the voltage shall be 5-27V DC, and the maximum input current shall be 27mA DC.

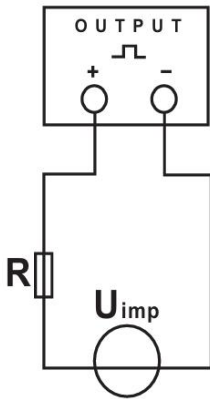

ATTENTION: Pulse output must be fed as shown in the wiring diagram on the left.

Scrupulously respect polarities and the connection mode.

Opto-coupler with potential-free SPST-NO Contact.

Contact range: 5~27VDC

Max. current Input: 27mA DC

## Chapter 2. Technical Parameters

### 2.1 Specifications

Electrical Characteristics		
Type of Measurement	RMS	
Measurement Accuracy	Voltage	± 0.2%
	Current	± 0.2%
	Frequency	± 0.05%
	Power Factor	± 0.005
	Active Power	1.0: 2%~10% 1% 10%~IMAX 0.5%
		0.5L/0.8C: 5%~20% 1% 20%~IMAX 0.6%
	Reactive Power	1.0: 5%~10% 2.5% 10%~IMAX 2%
		0.5L/C: 10%~20% 2.5% 20%~IMAX 2% 0.25L/C: 20%~IMAX 2.5%
	Apparent Power	5%~10% 1% 10~IMAX 0.5%
	Active Energy	Class 0.5 IEC62053-21 Class C EN50470-3:2022
Reactive Energy	Class 2 IEC 62053-23	
Technical parameters	Voltage AC (Un)	230VAC
	Voltage Range	100-277V AC(L-N)
	Frequency	50/60Hz
	Current Input	0.15-10(100)A
	Maximum Current	100A
	Minimum Current	0.15A
	Starting Current (Ist)	0.04A
	Transition Current (Itr)	1A
	Over Current Withstand	30Imax for 0.01S
	AC Voltage Withstand	4KV/1min
	Impulse Voltage Withstand	6kV – 1.2/50μS waveform
	Voltage Circuit Power Consumption	≤ 2W/10VA
	Current Circuit Power Consumption	≤3VA
	Display	LCD with white backlit
Mechanical Characteristics		
Net Weight	≈162g	
IP Degree of Protection (IEC 60529)	IP51 Front Display IP20 Whole Meter	
Dimensions (WxHxD)	36* 100* 63mm	
Mounting	DIN Rail 35mm	
Material of Meter Case	Self-extinguishing UL 94 V-0	

Mechanical Environment	M1
<b>Environmental Characteristics</b>	
Operating Temperature	-40 °C ~ +70 °C
Storage Temperature	-40 °C ~ +80 °C
Operation humidity	≤90% Non-condensing
Storage humidity	≤95% Non-condensing
Pollution Degree	II
Altitude	≤2000m
Vibration	10Hz ~ 150Hz, IEC 60068-2-6
<b>Electromagnetic Compatibility</b>	
Electrostatic Discharge	IEC 61000-4-2
Immunity to Radiated Fields	IEC 61000-4-3
Immunity to Fast Transients	IEC 61000-4-4
Surge (Impulse) Immunity	IEC 61000-4-5
Conducted Immunity	IEC 61000-4-6
Immunity to Magnetic Fields	IEC 61000-4-8
Immunity to Voltage Dips	IEC 61000-4-11
Radiated Emissions	CISPR 32
Conducted Emissions	CISPR 32
<b>Safety</b>	
Installation Category	CAT III
Over-voltage Category	CAT III
Protective Class	II
<b>Interface 1</b>	
Interface 1 Protocol	LoRaWAN Specification 1.0.2
Frequency	EU868/AS923/AU915...
LoRa WAN Class	Class C
Auto-upload	Max. 19 parameters
Auto-upload Interval	Configurable
Activation Way	OTAA or ABP
Output Power	13dBm in transmission
Coding Format	ASCII
<b>Pulse output 1 ( configurable )</b>	
Type	kWh/kVArh ( total, imported, exported) Default: exported KVArh
Constant	1, 10, 100, 1000 imp/kWh or kVArh Default: 1000 imp/kWh or kVArh
Width	200, 100, 60 ms Default:100ms
<b>Pulse output 2 ( fixed )</b>	
Type	imported kWh
Constant	1000imp/kWh
Width	100mS

**技术标准:**

[1] EN IEC61326-1: 2021 Electromagnetic Compatibility Directive - Electrical equipment for measurement, control and laboratory use - EMC requirements - Part 1: General requirements

[2] EN IEC 61326-2-3: 2021 Electromagnetic Compatibility Directive

[3] EN61010-1:2010+A1:2019 Low Voltage Directive 2014/35/EU - Safety requirements for electrical equipment for measurement, control, and laboratory use - Part 1: General requirements

[4] EN61010-2-030:2010 Low Voltage Directive 2014/35/EU - Particular requirements for testing and measuring circuits

- [5] EN 50470-3:2022 Electricity metering equipment - Part 3: Particular requirements - Static meters for AC active energy (class indexes A, B and C)
- [6] EN IEC 62052-11:2021/A11:2022, Electricity metering equipment - General requirements, tests and test conditions - Part 11: Metering equipment
- [7] IEC 62052-31:2015 Electricity metering equipment (AC) – General requirements, tests and test conditions – Part 31: Product safety requirements and tests

## 2.2 Dimensions

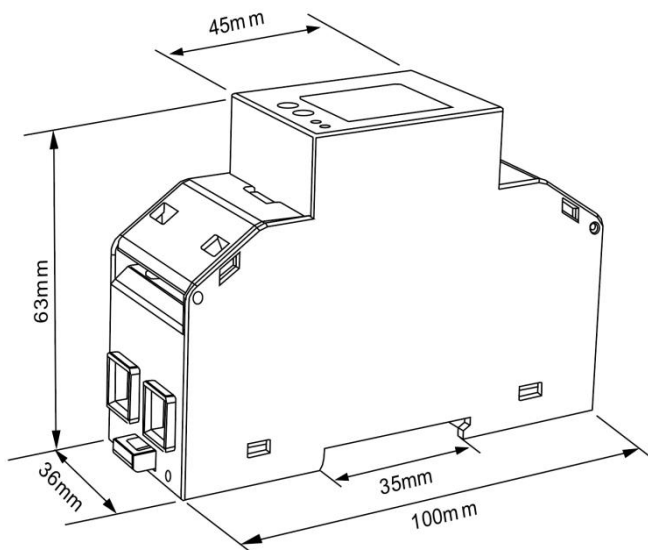

Height: 100mm  
Width: 36mm  
Depth: 63mm

## 2.3 Mounting

Step 1: Select a 35mm-wide DIN rail, Pull down the back-end clip on the meter to unlock the mounting mechanism.

Step 2: Align Upper Slot with DIN Rail. Position the upper slot of the meter's DIN rail groove onto the DIN rail, ensuring full contact (see Figure 1).

Step 3: Following the direction indicated in Figure 1, engage the lower slot of the DIN rail groove onto the DIN rail until audibly seated (see Figure 2).

Step 4: Push up the back-end clip to lock the meter firmly onto the DIN rail (see Figure 3).

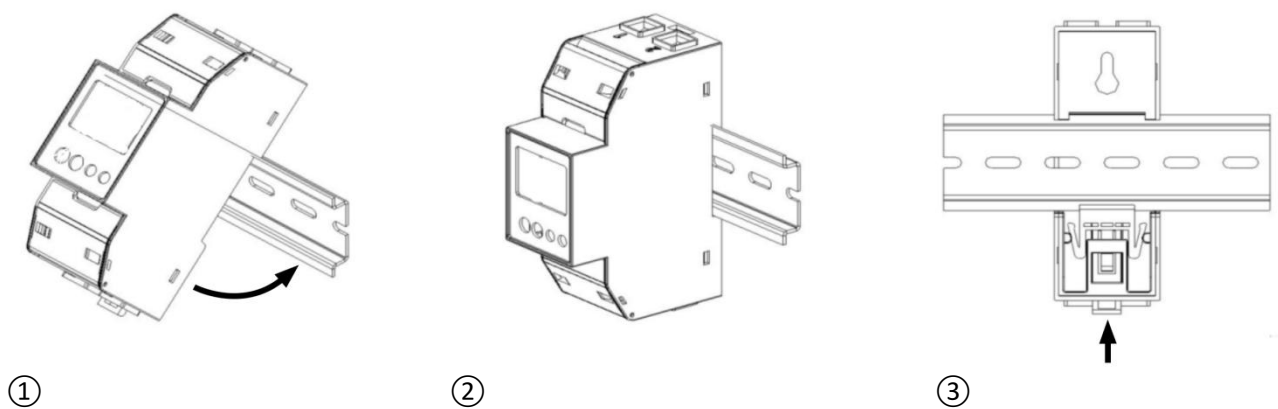

## 2.4 Wiring Diagram

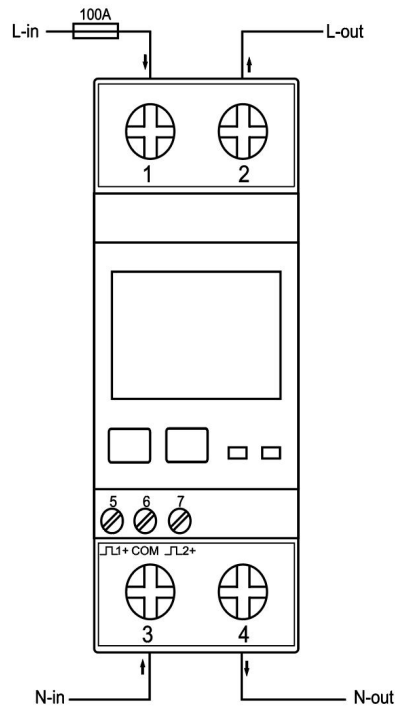

### Wiring Guide

Terminal ①~④	Measurement Connection	Screw Connection
	Strip Length	17-18mm
	Screw	M7
	Rigid/Supple	4-35mm <sup>2</sup> (11~2AWG)
	Tightening Torque	3Nm
	Model	PH3
Terminal ⑤~⑦	Measurement Connection	Screw Connection
	Strip Length	5-6mm
	Rigid/Supple	0.5-1.5mm <sup>2</sup> (22 ~ 14AWG)
	Tightening Torque	0.4Nm
	Model	PH0



## Chapter 3. Operation

### 3.1 Button Function



There are two keys on the panel, and the key operations are divided into two types: long press and short press:

Long press: Press and hold the key for more than 3 seconds.

Short press: Release the key within 1 second after pressing.

Button	Short click		Long press (3s)	
	Display mode	Setup mode	Display mode	Setup mode
	Switch display screens	Next page or decrease value		Return to the previous menu
		Move to right side	Enter Setup mode	Confirm setting

### 3.2 Installation Display

	The first screen lights up all display segments and can be used as a display check.
	The second screen show software version. Note: the actual display may be differ from the picture show in left.
	The third screen show program number. Note: the actual display may be differ from the picture show in left.

	<p>The interface performs a self-test and indicates the result if the test passes.</p>
--	--

### 3.3 Basic information display













Each successive pressing of the button selects a new range:



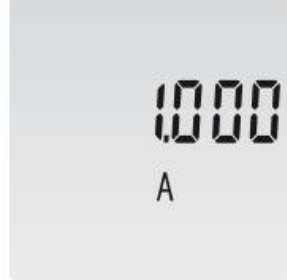

Can be viewed by pressing the button:

Total active energy in kWh → Imported active energy in kWh → Exported active energy in kWh → Resettable total active energy → Total reactive energy in kVAh → Imported reactive energy in kVAh → Exported reactive energy in kVAh → Resettable total reactive energy → Maximum total power demand → voltage → Current → Instantaneous active power in W → Instantaneous reactive power in VAR → Instantaneous volt-amps in VA → Power factor → Frequency → Pulse constant → Modbus address → Device high-address → Device low-address → Total running time

	<p>Total active energy in kWh</p>
	<p>Imported active energy in kWh</p>

 <p>EXP 00000.08 kWh</p>	Exported active energy in kWh
 <p>Σ r 00008.88 kWh</p>	Resettable total active energy
 <p>Σ 00000.68 kVArh</p>	Total reactive energy in kVArh
 <p>IMP 00000.60 kVArh</p>	Imported reactive energy in kVArh
 <p>EXP 00000.08 kVArh</p>	Exported reactive energy in kVArh

	Resettable total reactive energy
	Maximum total power demand
	voltage
	Current
	Instantaneous active power in W



 <p>A digital display showing the value '0' in large digits, with 'VAr' printed below it.</p>	Instantaneous reactive power in VAr
 <p>A digital display showing the value '0' in large digits, with 'VA' printed below it.</p>	Instantaneous volt-amps in VA
 <p>A digital display showing the value '1.000' in large digits, with 'PF' printed below it.</p>	Power factor
 <p>A digital display showing the value '50.00' in large digits, with 'Hz' printed below it.</p>	Frequency
 <p>A digital display showing the value '0.95t 1000' in large digits.</p>	Pulse constant

	Device high-address
	Device low-address
	Total running time

### 3.4 Auxiliary information display







Settings interface	Description
	Firmware CRC value







### 3.5 LoRa Setting

Settings interface	Description
	Network Configuration Screen
	Network configuration failed
	Network configuration error

### 3.6 Setup Mode 1



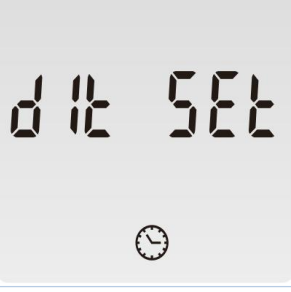
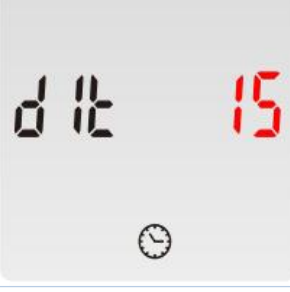

The meter's settable parameters are password protected. Long pressing on the  button will allow you to enter the setup mode. Some menu items, such as password, require a four-digit number entry, while others require selection from a number of menu options, such as baud rate.

1. Long press  button, entering the password "1000", long-press again to enter setup mode;
2. Short press  button, select the settings menu;
3. Long press  button to access the edit interface, short press  button to select the required settings, long-press  again to confirm the setting;
4. Long press  button to return to the higher menu level.



Settings interface	Set status	Optional configuration
		<b>Password</b> Default: 1000
		<b>Pulse output setting</b> Option: kWh or kVArh, imported, exported or total. Default: exported kWh
		<b>Pulse const setting</b> Option: 1, 10, 100, 1000 imp/kWh or kVArh Default: 1000 imp/kWh or kVArh
		<b>Pulse duration setting</b> Option: 200, 100, 60mS Default: 100mS
		<b>Demand interval time setting</b> Option: OFF, 5, 10, 15, 30, 60min Default: 15min

		<p><b>Auto-Cycle display time setting</b> Range: 00~30S Default: 0S</p>
		<p><b>Backlit time setting</b> Option: OFF, 5, 10, 20, 30, 60min Default: 60min</p>
		<p><b>CLR</b> Option: Max. demand, resettable energy</p>
		<p><b>Password setting</b> Range: 0000~9999 Default: 1000</p>
		<p><b>DevEui: end-device identifier</b> ***** (16 digits) Displayed on pages P1 to P4</p>
		<p><b>AppEui: application identifier</b> ***** (16 digits) Displayed on pages P1 to P4</p>

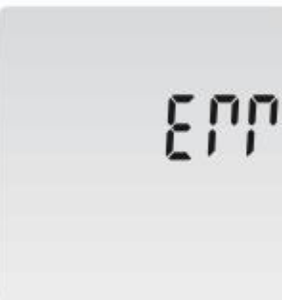
		<p><b>AppKey: application key</b>                  ***** (32 digits)                  Displayed on pages P1 to P8</p>
		<p><b>View ADR setting</b></p>
		<p><b>Join status</b>                  W (waiting to join the network), OK (network access successful), F (network access failed)</p>
		<p><b>View Join mode setting</b>                  display: OTAA, ABP</p>
		<p><b>Auto</b>                  1.Upload                  Option: ON/OFF</p>

		<p>2.Interval Time                  Option: 5, 30, 60, 90, 120, 150, 180, 210, 240 min                  Default: 30 min</p>
		<p><b>Dev address</b>                  ***** ( 8 digits)                  Displayed on pages P1 to P2</p>
		<p>Display prompt characters for successful or failed setting</p>

### 3.7 Setup Mode 2

Long press  button, entering the password "2308", long-press  and  button to gether to enter setup mode 2.

In set up mode 2, all the changes must be saved by performing a long press on the Save screen.

Settings interface	Set status	Optional configuration
		<p><b>Password</b>                  Default: 2308</p>

		<p><b>Join status</b></p>
		<p><b>DevEui: end-device identifier setting</b>                  *****(16 digits)</p>
		<p><b>AppEui: application identifier setting</b>                  *****(16 digits)</p>
		<p><b>Appkey : application key setting</b>                  *****(32 digits)</p>
		<p><b>ADR setting</b>                  Option: ON, OFF</p>
		<p><b>Confirm Mode</b>                  Option: ON, OFF</p>

		<p><b>Join mode</b> Option: OTAA, ABP</p>
		<p><b>SAVE setting</b></p>
		<p><b>Re-JOIN setting</b> *This function allows the meter re-join the network when disconnected.</p>
		<p><b>Auto upload setting</b></p>
		<p><b>Join delay setting</b> Option: ON, OFF</p>
		<p><b>OFFLINE setting</b> Option: 0, 30, 60, 90, 120, 150, 180, 210, 240min Default: 30 min</p>

## Chapter 4. LoRaWAN

### 4.1 LoRaWAN Classes

Eastron LoRaWAN energy meter is Class C functionality. The device will upload message after receiving the data sent from the network.

### 4.2 Active Upload Mode

The device also can be customized to active upload mode. Total 30 parameters can be set for automatic uploading.

Interval time can be set from 0 to 255 through communication. 0 means the function is OFF. If there are many parameters, the interval shouldn't be set too short in case of conflicting on data uploading.

The meter will upload automatically once it joins the network. And after the interval time, it will upload again. The interval time is calculated since the last data uploaded. Sometimes the interval time may have around 1-2 minutes difference due to the time error.

### 4.3 Join

The unit uses standard LoRaWAN protocol for long range communication. Before Communication, the meter has to join the LoRaWAN network first.

There are two Activation Ways for Joining: OTAA(Over-the-Air Activation) and ABP(Activation by Personalization). To ensure the meter joins the gateway successfully, below information must be confirmed:

- I. DevEui, AppEui, Appkey or DevAddr, NwkSKey, AppSKey information are correctly recorded into the gateway.
- II. The Uplink and downlink frequency is the same as the gateway.
- III. RX2 (frequency and SF) information is the same as the gateway.

If the Join delay function is ON, the meter will join the network with a few seconds delay by random.

### 4.4 Join Delay

When Join delay function is ON, the meter will join the LoRaWAN network with a few seconds delay after booting.

When Join delay function is OFF, the meter will join the LoRaWAN network once the power is on.

### 4.5 Communication

LoRaWAN meter communicates based on international general purpose protocol. The communication data is placed in data segment of LoRaWAN protocol, they will be appointed according to following specified command format.

The format of standard LoRaWAN is shown below:

Radio PHY layer:						
Preamble	PHDR	PHDR_CRC	PHYPayload			CRC*
			MHDR	MACPayload	MIC	
			MHDR	FHDR	Fport	FRMPayload
					MIC	
Note: CRC* is only available on uplink messages						

The following description of the text defines the data in the segment of **FRMPayload** region in LoRaWAN protocol. The software in the PC only needs to get this part of data from gateway. According to the following protocol definition to parse the data.

The data format and encoding of meter communication protocol are modified based on the Modbus ASCII  
 2025 EASTRON ELECTRONIC. When electricity matter [www.eastrongroup.com](http://www.eastrongroup.com) 24

transmission mode. Remove the start and end characters from the Modbus ASCII transmission mode and change LRC validation to CRC validation.

Encoding of data: communication data is encoded with ASCII, and each byte of data is sent with two ASCII characters.

E.g.: a byte data 0x5b is encoded as two characters: 0x35 and 0x62 (ASCII code 0x35= "5", 0x62= "b")

Command format definition:

I: The data format of the gateway sending the copy command:

Reserved	Function Code	The first Address of The Register to Read Data	The Number of Registers to Read Data	CRC Check Codes
1byte	1byte	2byte	2byte	2byte

Note: the reserved bit is fixed as 0x01

II: the data format returned by the meter after receiving the copy command:

Reserved	Function Code	The Length of Data Returned	Specific Data Returned by The Meter	CRC Check Codes
1byte	1byte	1byte	N byte	2byte

Note: the reserved bit is fixed as 0x01

III: Note: the above commands need to be ASCII, so 1byte data will have 2 characters.

E.g.

1). Suppose to read the current data of the meter L1, the data sent by the gateway is the ASCII coded data as shown in the following table:

Reserved		Function Code		The first Address of The Register to Read Data				The Number of Registers to Read Data				CRC Check Codes				
0x01		0x04		0x00		0x06		0x00		0x02		0x91		0xca		Hexadecimal Data
0x30	0x31	0x30	0x34	0x30	0x30	0x30	0x36	0x30	0x30	0x30	0x32	0x39	0x31	0x63	0x61	ASCII Coded Data
"0"	"1"	"0"	"4"	"0"	"0"	"0"	"6"	"0"	"0"	"0"	"2"	"9"	"1"	"c"	"a"	ASCII Character

Note: the first address of the register of the meter L1 current is 00 06 and the number of registers is 2.

2) After receiving the above command, the meter will return the current L1 current data of the meter, as shown in the following table after ASCII coding.

Reserved		Function Code		The Length of Data Returned		current L1 current data of the meter						CRC Check Codes							
0x01		0x04		0x04		0x40		0xa0		0x00		0x00		0xee		0x66		Hexadecimal Data	
0x30	0x31	0x30	0x34	0x30	0x30	0x34	0x30	0x61	0x30	0x30	0x30	0x30	0x30	0x30	0x65	0x65	0x36	0x36	ASCII Coded Data
"0"	"1"	"0"	"4"	"0"	"0"	"4"	"0"	"a"	"0"	"0"	"0"	"0"	"0"	"0"	"e"	"e"	"6"	"6"	ASCII Character

Note: Assume that the current meter's L1 current is 5.0A, since the data is in floating point format, the Hex data is converted to 0x40, 0xa0, 0x00 and 0x00.

To ensure the successful communication, below information must be confirmed:

1. The command is sent through Class C mode.
2. The command is sent in ASCII format.

## Chapter 5. Declaration of Conformity ( For MID meter only)

We, Zhejiang Eastron Electronic Co., Ltd. hereby declare under our sole responsibility as the manufacturer that the Smart Single Phase Energy Meter SDM230-Lora corresponds to the production model described in the EU-type examination certificate and complies with the requirements of the Directive 2014/32/EU.

Type examination certificate number: T12800.

Identification number of the Notified Body: 0598.

If you have any question, please feel free to contact our sales team.

**Eastron Electronic Co., Ltd.**

No. 52, Dongjin Road, Nanhu, Jiaying, Zhejiang, China

Tel: +86-573-83698881 Fax: +86-573-83698883

Email: [sales@eastrongroup.com](mailto:sales@eastrongroup.com)

[www.eastrongroup.com](http://www.eastrongroup.com)

