

SDM72D-M

Smart Three Phase Four Wire Energy Meter



USER MANUAL
2026 V1.1

Statements

All rights reserved. Without the written permission of the company, no paragraphs or chapters in this manual can be extracted, copied or reproduced in any form. Otherwise, the violator shall bear all consequences.

Eastron reserves all legal rights.

Eastron reserves the right to amend the product specifications in this manual without prior notice. Before placing an order, please contact our company or local agent to get the latest specifications.

CONTENT

Version History	1
Risk Information	2
Chapter 1. Introduction	4
1.1 Product Introduction	4
1.2 Product Characteristics	4
1.3 Application Scenarios	4
Chapter 2. Technical Parameters	5
2.1 Specifications	5
2.2 Dimensions	7
2.3 Mounting	7
2.4 Wiring Diagram	7
Chapter 3. Operation	10
3.1 Button Functions	10
3.2 Installation Display	10
3.3 Basic information display	11
3.4 Auxiliary information display	15
3.5 Setup Mode	15
Chapter 4. Declaration of Conformity (For MID meter only)	18

Version History

Version	Date	Changes
1.0	2025-04-21	Initial issue
1.1	2026-04-07	Update to the latest layout

Risk Information

Information for Your Own Safety

This manual does not contain all of the safety measures for operating the equipment (module, device) for different conditions and requirements. However, it does contain information which you must know for your own safety and to avoid damages. This information is highlighted by a warning triangle, which indicates the degree of potential danger.



Warning

This means that failure to observe the instruction can result in death, serious injury or considerable material damage.



Caution

This means hazard of electric shock and failure to take the necessary safety precautions will result in death, serious injury or considerable material damage.

Qualified personnel

Operation of the equipment (module, device) described in this manual must only be performed by qualified personnel. Qualified personnel in this manual means people who are authorized to commission, start up, ground and label devices, systems and circuits in accordance with Safety Regulatory standards.

Proper handling

The prerequisites for perfect, reliable operation of the product are proper transport, storage, installation and operation and maintenance. When operating electrical equipment, some parts of this equipment automatically carry dangerous voltages. Improper handling can therefore result in serious injuries or material damages.

- ✧ Use only insulating tools.
- ✧ Do not connect while circuit is live (hot).
- ✧ Place the meter only in dry surroundings.
- ✧ Do not mount the meter in an explosive area or expose the meter to dust, mildew and insects.
- ✧ Make sure the wires are suitable for the maximum current of this meter.
- ✧ Make sure the AC wires are connected correctly before activating the current/voltage to the meter.
- ✧ Do not touch the clamps directly with metal, blank wire or your bare hands as you may get electrical shock.
- ✧ Make sure the protection cover is placed after installation.
- ✧ Installation, maintenance and reparation should only be done by qualified personnel.
- ✧ Never break the seals or open the front cover as this might influence the function, and will void the warranty.
- ✧ Do not drop, or allow strong physical impact on the meter as the high precisely components inside may be damaged.
- ✧ This product is designed to be mounted inside of switchboards or cabinet on DIN rail.
- ✧ This device must have a suitable sized Circuit Breaker feeding the Multi Function Energy Meter so it does not

exceed the maximum rated current.

- ✧ The supply wiring of this device shall be suitable sized cable to match the installed circuit breaker.
- ✧ A Disconnection Device (Circuit Breaker) should be installed close to the Multi Function Energy Meter.
- ✧ The Disconnection Device shall be marked as the Disconnection Device for the Multi Function Energy Meter.

Disclaimer

We have checked the contents of this publication and every effort has been made to ensure that the descriptions are as accurate as possible.

However, deviations from the description cannot be completely ruled out, so that no liability can be accepted for any errors contained in the information given. The data in this manual is checked regularly and the necessary corrections are included in subsequent editions. We are grateful for any improvements that you suggest.

Chapter 1. Introduction

1.1 Product Introduction

The SDM72D-M is a 3 phase energy meter with white back-lighted LCD screen for perfect reading. The unit measures and displays voltage, current, frequency, power factor, active power, reactive power, active energy and reactive energy, etc. A resettable partial energy is provided, the user can easily check the active energy imported and active energy exported during a certain period. SDM72D-M supports max.100A direct connection, saving the cost and avoiding the trouble to connect external CTs, giving the unit a cost-effective and easy operation. Built-in interfaces provide pulse and RS485 Modbus RTU outputs. Configuration is password protected.

1.2 Product Characteristics

- Bi-directional measurement IMP & EXP
- RS485 Modbus RTU
- Multi-parameters measurement
- LCD with white backlit, adjustable backlit time

Measurements:

- Phase voltage: V1, V2, V3
- Line voltage: V1-2, V2-3, V3-1
- Current: I1, I2, I3
- Active power: P1, P2, P3, P_total (total active power)
- Reactive power: Q1, Q2, Q3, Q_total (total reactive power)
- Frequency: Hz
- Power factor: PF
- Active energy: Ep_imp (import active energy), Ep_exp (export active energy), Ep_total (total active energy)
- Reactive energy: Eq_imp (import reactive energy), Eq_exp (export reactive energy), Eq_total (total reactive energy)

Setup:

- Modbus parameters
- Pulse parameters
- Backlit time
- Supply system 1p2w, 3p4w
- Password modification
- Clear resettable energy info

1.3 Application Scenarios

The SDM72D-M is a three-phase energy meter for industrial, commercial and residential power monitoring. Supporting direct connection up to 100A, it suits distribution cabinets, building energy management, PV self-consumption, and EV charging. Built-in RS485 (Modbus RTU) and pulse output enable real-time energy monitoring and remote management.

Chapter 2. Technical Parameters

2.1 Specifications

Electrical Characteristics		
Type of Measurement	RMS	
Measurement Accuracy	Voltage	± 0.5%
	Current	± 0.5%
	Frequency	± 0.1%
	Power Factor	± 0.01
	Active Power	± 1%(10%I _b ~I _{max})
	Reactive Power	± 1%(10%I _b ~I _{max})
	Apparent Power	± 1%(10%I _b ~I _{max})
	Active Energy	Class 1 IEC62053-21 Class B EN50470-3:2022
	Reactive Energy	Class 2 IEC 62053-23
Technical parameters	Voltage AC (Un)	3*230/400VAC
	Voltage Range	100 - 277V AC(L-N) 100 to 480V AC (L-L)
	Frequency	50/60Hz
	Current Input	10A
	Maximum Current	100A
	Minimum Current	0.5A
	Starting Current (I _{st})	0.04A
	Transition Current (I _{tr})	1A
	Over Current Withstand	30I _{max} for 0.01S
	AC Voltage Withstand	4KV/1min
	Impulse Voltage Withstand	6kV – 1.2/50μS waveform
	Voltage Circuit Power Consumption	≤ 2W/10VA
	Current Circuit Power Consumption	≤2VA
	Display	LCD with white backlit
	Max. reading	999999.9 kWh/kVAh
Mechanical Characteristics		
Net Weight	≈325g	
IP Degree of Protection (IEC 60529)	IP51 Front Display IP20 Whole Meter	
Dimensions (WxHxD)	72* 100* 66mm	
Mounting	DIN Rail 35mm	
Material of Meter Case	Self-extinguishing UL 94 V-0	
Mechanical Environment	M1	
Environmental Characteristics		

Operating Temperature	-40°C ~ +70°C
Storage Temperature	-40°C ~ +80°C
Operation humidity	≤90% Non-condensing
Storage humidity	≤95% Non-condensing
Pollution Degree	II
Altitude	≤2000m
Vibration	10Hz ~ 50Hz, IEC 60068-2-6
Electromagnetic Compatibility	
Electrostatic Discharge	IEC 61000-4-2
Immunity to Radiated Fields	IEC 61000-4-3
Immunity to Fast Transients	IEC 61000-4-4
Surge (Impulse) Immunity	IEC 61000-4-5
Conducted Immunity	IEC 61000-4-6
Immunity to Magnetic Fields	IEC 61000-4-8
Immunity to Voltage Dips	IEC 61000-4-11
Radiated Emissions	CISPR 32
Conducted Emissions	CISPR 32
Safety	
Installation Category	CAT III
Over-voltage Category	CAT III
Protective Class	II
Interface 1	
Interface 1 Protocol	Modbus-RTU
Communication Address	1 - 247
Transmission Mode	Half Duplex
Data Type	Floating Point
Transmission Distance	1000m Maximum
Transmission Speed	2400/4800/9600(Default)/19200/38400bps
Parity	NONE(Default)/ODD/EVEN
Stop Bits	1/2
Response Time	<100 ms
Pulse output 1 (configurable)	
Type	kWh(total, imported, exported) Default: total kWh
Constant	1, 10, 100, 1000 imp/kWh Default: 1000 imp/kWh
Width	200, 100, 60ms Default: 35ms
Pulse output 2(Fixed)	
Type	imported kWh & exported kWh
Constant	1000imp/kWh
Width	100ms

Technical Standards:

- [1] EN IEC61326-1: 2021 Electromagnetic Compatibility Directive - Electrical equipment for measurement, control and laboratory use - EMC requirements - Part 1: General requirements
- [2] EN IEC 61326-2-3: 2021 Electromagnetic Compatibility Directive
- [3] EN61010-1:2010+A1:2019 Low Voltage Directive 2014/35/EU - Safety requirements for electrical equipment for measurement, control, and laboratory use - Part 1: General requirements
- [4] EN61010-2-030:2010 Low Voltage Directive 2014/35/EU - Particular requirements for testing and measuring circuits
- [5] EN 50470-3:2022 Electricity metering equipment - Part 3: Particular requirements - Static meters for AC active energy (class indexes A, B and C)
- [6] EN IEC 62052-11:2021/A11:2022, Electricity metering equipment - General requirements, tests and test conditions - Part 11: Metering equipment
- [7] IEC 62052-31:2015 Electricity metering equipment (AC) – General requirements, tests and test conditions – Part 31: Product safety requirements and tests
- [8] IEC 62053-21:2021 Electricity metering equipment – Particular requirements – Part 21: Static meters for AC active energy (classes 0,5, 1 and 2)

2.2 Dimensions

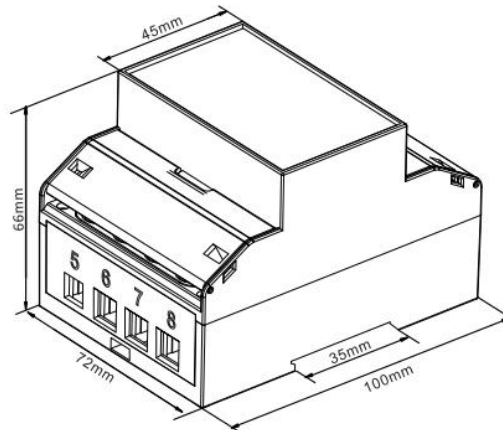

Width: 72 mm
Height: 100 mm
Depth: 66mm

2.3 Mounting

Step 1: Select a 35mm-wide DIN rail, Pull down the back-end clip on the meter to unlock the mounting mechanism.

Step 2: Align Upper Slot with DIN Rail. Position the upper slot of the meter's DIN rail groove onto the DIN rail, ensuring full contact (see Figure 1).

Step 3: Following the direction indicated in Figure 1, engage the lower slot of the DIN rail groove onto the DIN rail until audibly seated (see Figure 2).

Step 4: Push up the back-end clip to lock the meter firmly onto the DIN rail (see Figure 3).

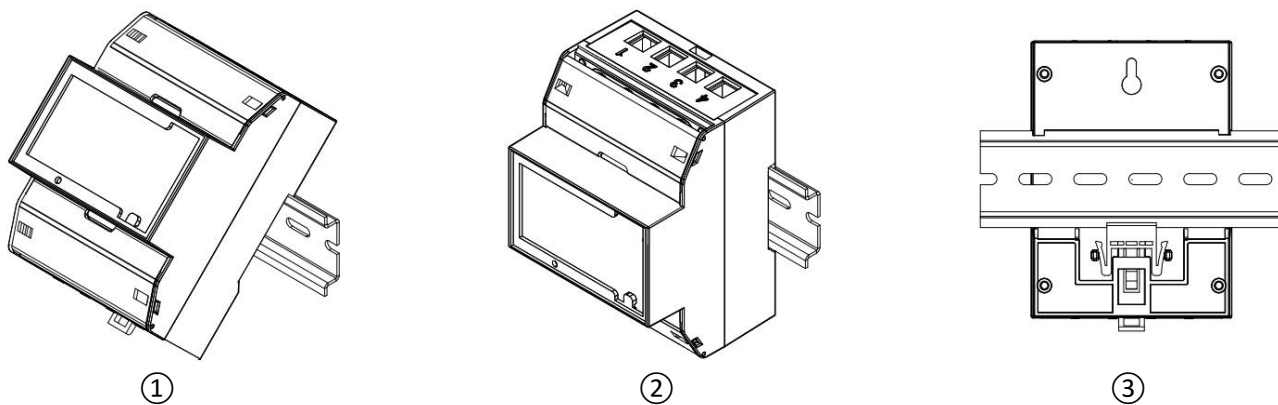

2.4 Wiring Diagram

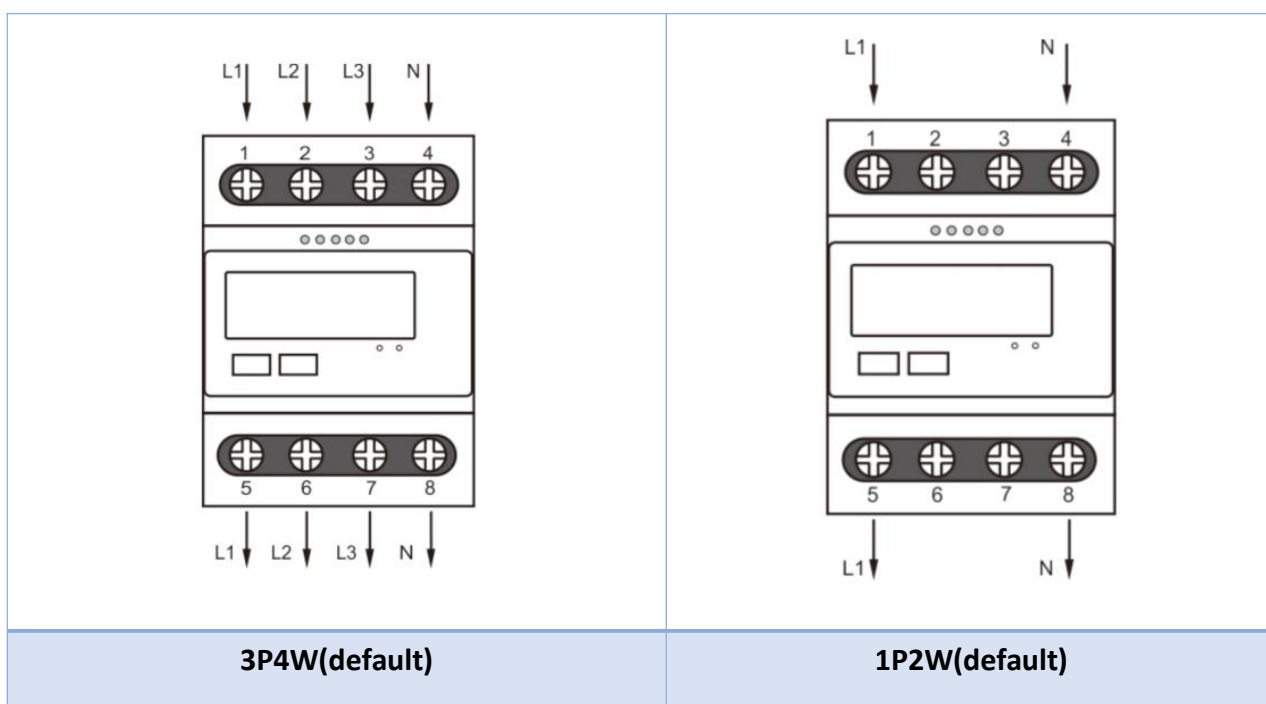

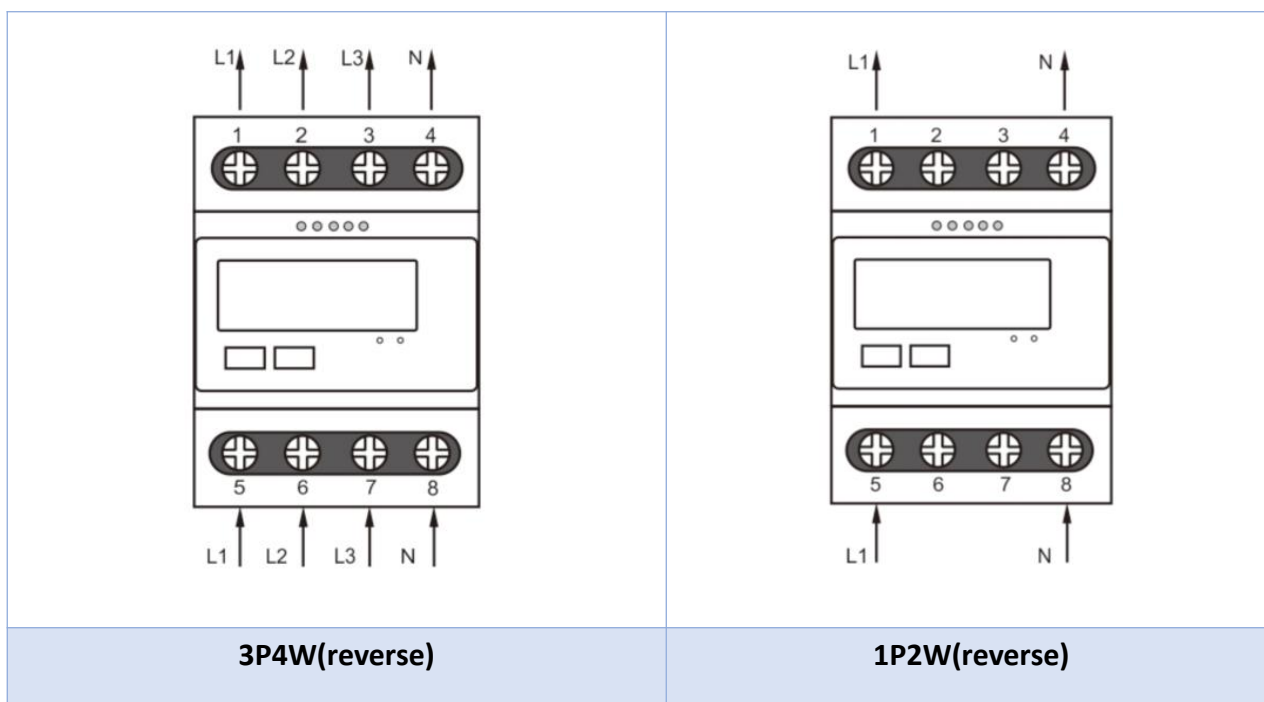



Wiring Guide

Terminal ①~⑧	Measurement Connection	Screw Connection
	Strip Length	12-13mm
	Screw	M5
	Rigid/Supple	4-25mm ² (11~4AWG)
	Tightening Torque	3.5Nm
	Model	PH2
Terminal B- A+ -L+	Measurement Connection	Screw Connection
	Strip Length	6-7mm
	Rigid/Supple	0.5-1.5mm ² (26 ~ 14AWG)
	Tightening Torque	0.4Nm
	Model	PH0

Chapter 3. Operation





3.1 Button Functions

The buttons operate as follows:

Button	Short click		Long press (3s)	
	Display mode	Setup mode	Display mode	Setup mode
	Switch display screens	next page or increase value	Cyclic redundancy check code	Return to the previous menu
		Move to right side	Enter Setup mode	Confirm setting

3.2 Installation Display

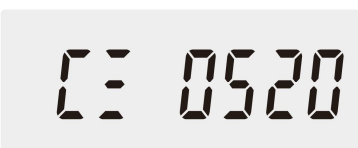
Connect the wire and power on the meter to enter the normal measurement state. The screen display is as follows:

	The first screen lights up all display segments and can be used as a display check
	The second screen show software version
	The third screen shows program number
	The fourth screen show Pulse constant

3.3 Basic information display















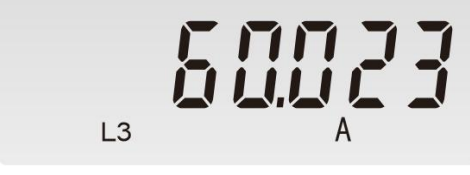

Each successive pressing of the button selects a new range:



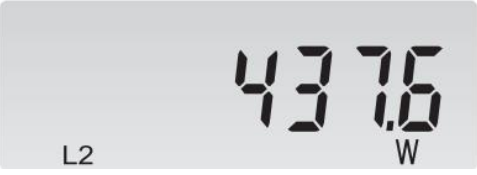
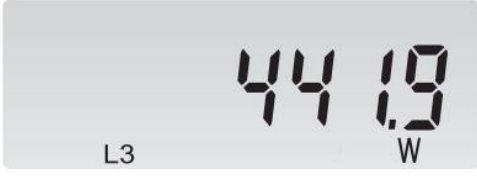

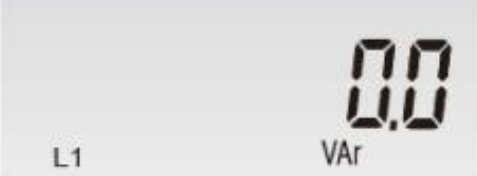

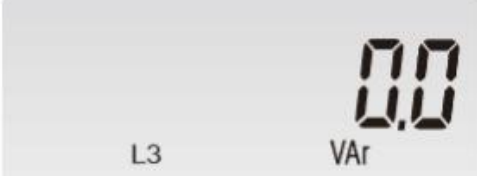

Can be viewed by pressing the button:

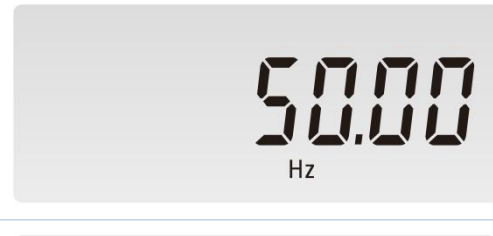

Total active energy → Resettable total active energy → Imported active energy in kWh → Exported active energy in kWh → Total reactive energy in kVArh → Resettable total reactive energy → L1-N voltage → L2-N voltage → L3-N voltage → L1 current → L2 current → L3 current → L1 active power → L2 active power → L3 active power → Total active power → L1 reactive power → L2 reactive power → L3 reactive power → Total reactive power → L1 power factor → L2 power factor → L3 power factor → Total power factor → Frequency → Pulse output type & Pulse constant → Modbus address → Baud rate → Parity bit → Software version

	Total active energy
	Resettable total active energy
	Imported active energy in kWh
	Exported active energy in kWh
	Total reactive energy in kVArh

 <p>Total 00028.67 kVArh</p>	<p>Resettable total reactive energy</p>
 <p>L1 230.0 V</p>	<p>L1-N voltage</p>
 <p>L2 230.1 V</p>	<p>L2-N voltage</p>
 <p>L3 230.2 V</p>	<p>L3-N voltage</p>
 <p>L1 60.023 A</p>	<p>L1 current</p>
 <p>L2 60.023 A</p>	<p>L2 current</p>
 <p>L3 60.023 A</p>	<p>L3 current</p>

 <p>L1 450.4 W</p>	L1 active power
 <p>L2 437.6 W</p>	L2 active power
 <p>L3 441.9 W</p>	L3 active power
 <p>Total 0.0 W</p>	Total active power
 <p>L1 0.0 VAR</p>	L1 reactive power
 <p>L2 0.0 VAR</p>	L2 reactive power
 <p>L3 0.0 VAR</p>	L3 reactive power
 <p>Total 0.0 VAR</p>	Total reactive power

 <p>L1</p>	L1 power factor
 <p>L2</p>	L2 power factor
 <p>L3</p>	L3 power factor
 <p>Total</p>	Total power factor
 <p>Hz</p>	Frequency
 <p>Total</p> <p>kWh</p>	Pulse output type & Pulse constant •
	Modbus address
 <p>k</p>	Baud rate

	Parity bit
	Software version

3.4 Auxiliary information display





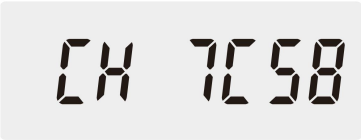
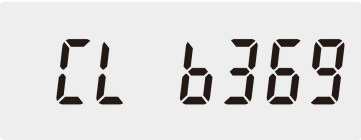

Each successive Long pressing of the  button enter the auxiliary mode:

	CRC-high bytes
	CRC-low bytes













3.5 Setup Mode







The meter's settable parameters are password protected. Each successive long pressing on the  button to enter setup mode. Some menu items, such as password, require a four-digit number entry while others, such as baud rate, require selection from a number of menu options.

1. Long press  button, after entering the password, long-press again to enter setup mode;
2. Short press  button, select the setting menu;
3. Long press  button to access the edit interface, short press  button to select the required settings,

long-press  again to confirm the setting;

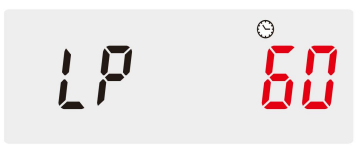
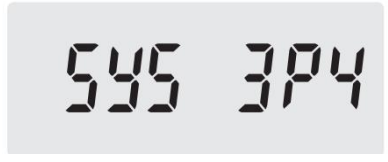
4. Long press  button to return to the higher menu level.

Settings interface	Set status	Optional configuration
		Password Default: 1000
		Modbus address setting Range: 001~247 Default: 001
		Baud rate setting Option: 2.4k, 4.8k, 9.6k, 19.2k, 38.4kbps default: 9.6kbps
		Parity bit setting Option: EVEN, ODD, NONE Default: NONE
		Stop bit setting Option: 1, 2 Default: 1
		Pulse output setting Option: kWh (import, export or Total) Default: Total kWh
		Pulse const setting Option: 1, 10, 100, 1000 imp/kWh Default: 1000 imp/kWh

		<p>Pulse duration setting Option: 200, 100, 60ms Default: 35ms Note:When pulse constant is 1000imp/kWh, pulse width is fixed at 35ms and can not be adjusted.</p>
		<p>Wheel display time setting Range: 00~60S Default: 0</p>
		<p>Backlit time setting Option: ON, OFF, 5, 10, 20, 30, 60, 120min Default: 60min</p>
		<p>System type setting Option: 3P4W, 1P2W Default: 3P4W</p>
		<p>Password Range: 0000~9999 Default: 1000</p>
		<p>CLR resettable energy</p>

Chapter 4. Declaration of Conformity (For MID meter only)

We, Zhejiang Eastron Electronic Co., Ltd. declares under our sole responsibility as the manufacturer that the three phase multi-function electrical energy meter SDM72D-M correspond to the production model described in the EU-type examination certificate and the requirements of the Directive 2014/32/EU.

Type examination certificate number T12831.

Identification number of the Notified Body: 0598.

IF you have any question, please feel free to contact our sales team.

Zhejiang Eastron Electronic Co., Ltd.

No.52, DongJin Rd. Jiaxing, Zhejiang, 314001, China

Tel: 400-996-9296 Fax: +86-573-83698883

Email: sales@eastrongroup.com

www.eastrongroup.com

