

# SDM630MCT-RC

*Smart Three Phase Energy Meter*



**USER MANUAL**  
**2026 V1.1**

## Statements

All rights reserved. Without the written permission of the company, no paragraphs or chapters in this manual can be extracted, copied or reproduced in any form. Otherwise, the violator shall bear all consequences.

Eastron reserves all legal rights.

Eastron reserves the right to amend the product specifications in this manual without prior notice. Before placing an order, please contact our company or local agent to get the latest specifications.

# CONTENT

Version History .....	1
Risk Information .....	2
Chapter 1. Introduction .....	4
1.1 Product Introduction .....	4
1.2 Product Characteristics .....	4
1.3 Application Scenarios .....	5
Chapter 2. Technical Parameters .....	6
2.1 Specifications .....	6
2.2 Dimensions .....	8
2.3 Mounting .....	8
2.4 Wiring Diagram .....	9
2.5 Rogowski Coils .....	10
2.5.1 Rogowski Coils Selection .....	10
2.5.2 Rogowski Coil Wiring Diagram .....	10
2.5.3 Rogowski Coil Setting .....	10
Chapter 3. Operation .....	11
3.1 Button Functions .....	11
3.2 Installation Display .....	11
3.3 Basic information display .....	12
3.3.1 Voltage and current .....	12
3.3.2 Frequency, Power factor and Demand .....	13
3.3.3 Power .....	14
3.3.4 Energy .....	15
3.4 Auxiliary information display .....	16
3.5 Setup Mode .....	16
3.5.1 Menu Option Selection .....	16
3.5.2 Number Entry Procedure .....	16

## Version History

Version	Date	Changes
1.0	2025-06-17	Initial issue
1.1	2026-03-24	Update to the new standard version

## Risk Information

### Information for Your Own Safety

This manual does not contain all of the safety measures for operating the equipment (module, device) for different conditions and requirements. However, it does contain information which you must know for your own safety and to avoid damages. This information is highlighted by a warning triangle, which indicates the degree of potential danger.



#### Warning

This means that failure to observe the instruction can result in death, serious injury or considerable material damage.



#### Caution

This means hazard of electric shock and failure to take the necessary safety precautions will result in death, serious injury or considerable material damage.

### Qualified personnel

Operation of the equipment (module, device) described in this manual must only be performed by qualified personnel. Qualified personnel in this manual means people who are authorized to commission, start up, ground and label devices, systems and circuits in accordance with Safety Regulatory standards.

### Proper handling

The prerequisites for perfect, reliable operation of the product are proper transport, storage, installation and operation and maintenance. When operating electrical equipment, some parts of this equipment automatically carry dangerous voltages. Improper handling can therefore result in serious injuries or material damages.

- ✧ Use only insulating tools.
- ✧ Do not connect while circuit is live (hot).
- ✧ Place the meter only in dry surroundings.
- ✧ Do not mount the meter in an explosive area or expose the meter to dust, mildew and insects.
- ✧ Make sure the wires are suitable for the maximum current of this meter.
- ✧ Make sure the AC wires are connected correctly before activating the current/voltage to the meter.
- ✧ Do not touch the clamps directly with metal, blank wire or your bare hands as you may get electrical shock.
- ✧ Make sure the protection cover is placed after installation.
- ✧ Installation, maintenance and reparation should only be done by qualified personnel.
- ✧ Never break the seals or open the front cover as this might influence the function, and will void the warranty.
- ✧ Do not drop, or allow strong physical Hit on the meter as the high precisely components inside may be damaged.
- ✧ This product is designed to be mounted inside of switchboards or cabinet on DIN rail.
- ✧ This device must have a suitable sized Circuit Breaker feeding the Multi Function Energy Meter so it does not

exceed the maximum rated current.

- ✧ The supply wiring of this device shall be suitable sized cable to match the installed circuit breaker.
- ✧ A Disconnection Device (Circuit Breaker) should be installed close to the Multi Function Energy Meter.
- ✧ The Disconnection Device shall be marked as the Disconnection Device for the Multi Function Energy Meter.

#### **Disclaimer**

We have checked the contents of this publication and every effort has been made to ensure that the descriptions are as accurate as possible.

However, deviations from the description cannot be completely ruled out, so that no liability can be accepted for any errors contained in the information given. The data in this manual is checked regularly and the necessary corrections are included in subsequent editions. We are grateful for any improvements that you suggest.

## Chapter 1. Introduction

### 1.1 Product Introduction

SDM630MCT-RC is Eastron's new-generation three-phase smart energy meter.

The meter measures and displays the characteristics of single phase two wire (1p2w), single phase three wire (1p3w), three phase three wire (3p3w) and three phase four wire (3p4w) supplies, including voltage, frequency, current, power, active and reactive energy, imported or exported. Energy is measured in terms of kWh, kVAh. Maximum demand current can be measured over preset periods of up to 60 minutes. In order to measure energy, the unit requires voltage and current inputs in addition to the supply required to power the product. The requisite current input(s) are obtained via Rogowski coils.

The meter can be configured to work with Rogowski coils without integrator. The ratio of connected Rogowski coils should be standard 85mV/kA. An RS485 communication port is available on the meter for remote data transmission.

This unit can be powered from a separate auxiliary AC power supply. Alternatively it can be powered from the monitored supply, where appropriate.

### 1.2 Product Characteristics

- Bi-directional measurement IMP & EXP
- RS485 Modbus RTU
- Multi-parameters measurement
- LCD with white backlit, adjustable backlit time

#### Measurements:

- Phase voltage: V1, V2, V3
- Line voltage: V1-2, V2-3, V3-1
- Current: I1, I2, I3, IN
- Active power: P1, P2, P3, P\_total (total active power)
- Reactive power: Q1, Q2, Q3, Q\_total (total reactive power)
- Apparent power: S1, S2, S3, S\_Total (total apparent power)
- Frequency: Hz
- Power factor: PF
- Active energy: Ep\_imp (import active energy), Ep\_exp (export active energy), Ep\_total (total active energy)
- Reactive energy: Eq\_imp (import reactive energy), Eq\_exp (export reactive energy), Eq\_total (total reactive energy)
- THD-I and THD-U
- Maximum demand: MD

#### Setup:

- RS485 Modbus RTU
- Demand interval time

- Backlit time
- Supply system 1p2w, 1p3w, 3p3w,3p4w
- Reset
- Password modification

### **1.3 Application Scenarios**

The SDM630MCT-RC is a three-phase multifunctional meter designed for applications such as industrial equipment, PV systems, EV charging stations, and data centers, featuring Rogowski coil input for easy installation on large conductors, bidirectional measurement, and RS485 Modbus RTU communication, aiming to provide users with flexible, accurate, and reliable energy monitoring and management.

## Chapter 2. Technical Parameters

### 2.1 Specifications

Electrical Characteristics		
Type of Measurement	RMS	
Measurement Accuracy	Voltage	± 0.5%
	Current	± 0.5%
	Frequency	± 0.2%
	Power Factor	± 0.01
	Active Power	± 1%(5%I <sub>b</sub> ~I <sub>max</sub> )
	Reactive Power	± 1%(5%I <sub>b</sub> ~I <sub>max</sub> )
	Apparent Power	±1%(5%I <sub>b</sub> ~I <sub>max</sub> )
	Active Energy	Class 0.5 IEC62053-21 Class C EN50470-3:2022
Reactive Energy	Class 2 IEC 62053-23	
Technical parameters	Auxiliary voltage range	100 to 277V AC/140 to 390V DC
	Voltage AC (Un)	3*230/400VAC
	Voltage Range	100 - 277V AC( L-N ) 100 to 480V AC ( L-L)
	Frequency	50/60Hz
	Current Input	85mV/kA
	Over Current Withstand	20I <sub>max</sub> for 0.5S
	AC Voltage Withstand	4KV/1min
	Impulse Voltage Withstand	6kV – 1.2/50μS waveform
	Voltage Circuit Power Consumption	≤ 2W/10VA
	Current Circuit Power Consumption	≤0.05VA
	Display	LCD with white backlit
	Max. reading	9999999.9 kWh/kVArh
	Mechanical Characteristics	
Net Weight	≈243g	
IP Degree of Protection (IEC 60529)	IP51 Front Display IP20 Whole Meter	
Dimensions (WxHxD)	72* 94.5* 65mm	
Mounting	DIN Rail 35mm	
Material of Meter Case	Self-extinguishing UL 94 V-0	
Mechanical Environment	M1	
Environmental Characteristics		
Operating Temperature	-40℃ ~ +70℃	
Storage Temperature	-40℃ ~ +80℃	
Operation humidity	≤90% Non-condensing	

Storage humidity	≤95% Non-condensing
Pollution Degree	II
Altitude	≤2000m
Vibration	10Hz ~ 150Hz, IEC 60068-2-6
<b>Electromagnetic Compatibility</b>	
Electrostatic Discharge	IEC 61000-4-2
Immunity to Radiated Fields	IEC 61000-4-3
Immunity to Fast Transients	IEC 61000-4-4
Surge (Impulse) Immunity	IEC 61000-4-5
Conducted Immunity	IEC 61000-4-6
Immunity to Magnetic Fields	IEC 61000-4-8
Immunity to Voltage Dips	IEC 61000-4-11
Radiated Emissions	CISPR 32
Conducted Emissions	CISPR 32
<b>Safety</b>	
Installation Category	CAT III
Over-voltage Category	CAT III
Current Inputs	Require External Current Transformer for Insulation
Protective Class	II
<b>Interface 1</b>	
Interface 1 Protocol	MODBUS RTU
Communication Address	1 to 247
Transmission Mode	Half Duplex
Data Type	Floating Point
Transmission Distance	1000m Maximum
Transmission Speed	2400/4800/9600(Default)/19200/38400bps
Parity	NONE(Default)/ODD/EVEN
Stop Bits	1(default) or 2
Response Time	<30 ms
<b>Interface 2</b>	
<b>Pulse output 1 ( configurable )</b>	
Type	kWh/kVArh ( total, imported, exported) Default:total KVArh
Constant	0.001, 0.01, 0.1, 1,10, 100, 1000 kWh/kVArh per imp Default: 0.01 kVArh/imp
Width	200, 100, 60 mS Default:200mS
<b>Pulse output 2 ( fixed )</b>	
Type	Total kWh
Constant	5000 imp/kWh
Width	100mS

**Technical Standards:**

- [1] EN IEC61326-1: 2021 Electromagnetic Compatibility Directive - Electrical equipment for measurement, control and laboratory use - EMC requirements - Part 1: General requirements
- [2] EN IEC 61326-2-3: 2021 Electromagnetic Compatibility Directive
- [3] EN61010-1:2010+A1:2019 Low Voltage Directive 2014/35/EU - Safety requirements for electrical equipment for measurement, control, and laboratory use - Part 1: General requirements
- [4] EN61010-2-030:2010 Low Voltage Directive 2014/35/EU - Particular requirements for testing and measuring circuits
- [5] EN 50470-3:2022 Electricity metering equipment - Part 3: Particular requirements - Static meters for AC active energy (class indexes A, B and C)
- [6] EN IEC 62052-11:2021/A11:2022, Electricity metering equipment - General requirements, tests and test conditions - Part 11: Metering equipment
- [7] IEC 62052-31:2015 Electricity metering equipment (AC) – General requirements, tests and test conditions – Part 31: Product safety requirements and tests
- [8] IEC62053-21-2020 Electricity metering equipment - Particular requirements -Part 21, Static meters for AC active energy (classes 0,5,1 and 2)

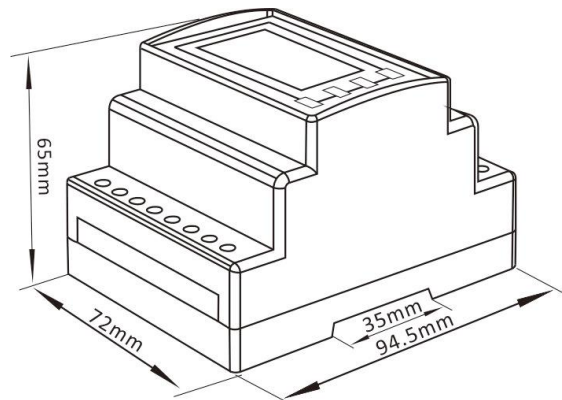
**2.2 Dimensions**

Width: 72 mm  
 Height: 94.5 mm  
 Depth: 65mm

**2.3 Mounting**

Step 1: Select a 35mm-wide DIN rail, Pull down the back-end clip on the meter to unlock the mounting mechanism.

Step 2: Align Upper Slot with DIN Rail. Position the upper slot of the meter's DIN rail groove onto the DIN rail, ensuring full contact (see Figure 1).

Step 3: Following the direction indicated in Figure 1, engage the lower slot of the DIN rail groove onto the DIN rail until audibly seated (see Figure 2).

Step 4: Push up the back-end clip to lock the meter firmly onto the DIN rail (see Figure 3).

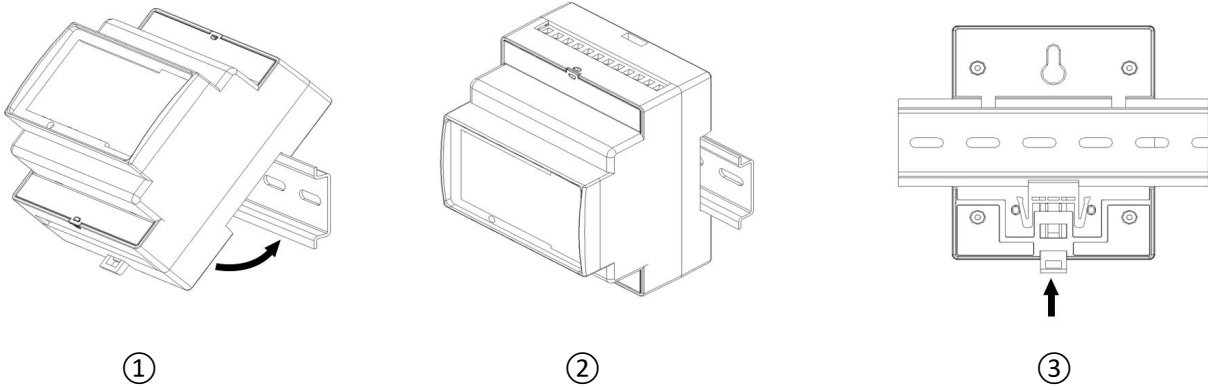

## 2.4 Wiring Diagram

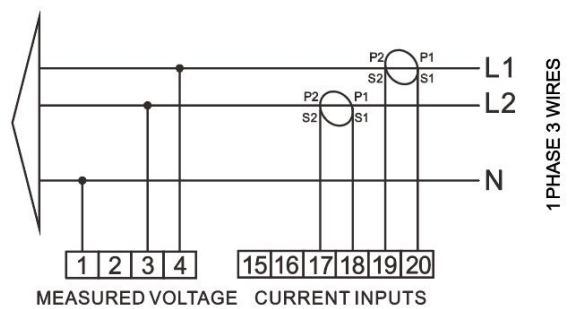
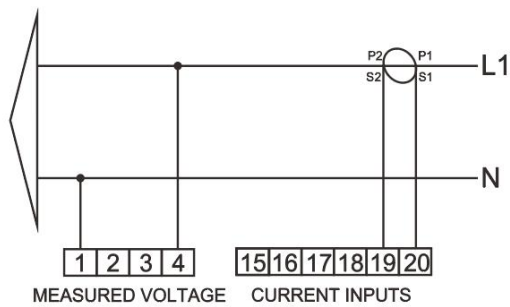
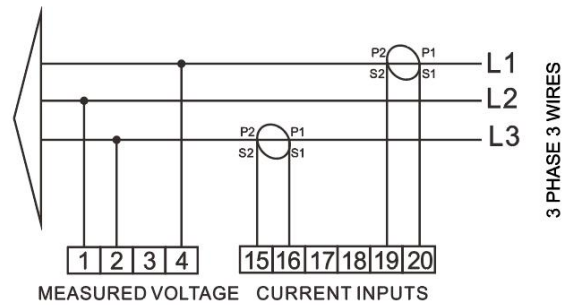
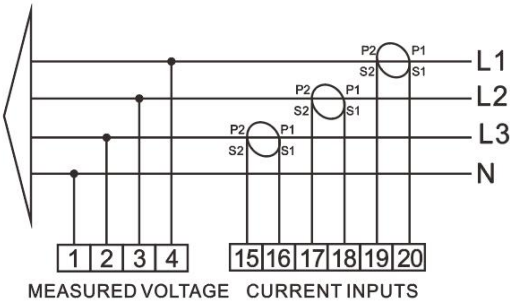
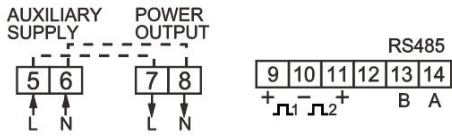

## Wiring Guide

Terminal ①~⑳	Measurement Connection	Screw Connection
	Strip Length	6-7mm
	Screw	M3
	Rigid/Supple	0.5-1.5mm <sup>2</sup> (22 ~ 14AWG)
	Tightening Torque	0.4Nm
	Model	PH0

## 2.5 Rogowski Coils

### 2.5.1 Rogowski Coils Selection

Coil code	Reference Rated Current	Class	Window Size(mm)	Coil Length(mm)
ESCT-RC60	500A	0.5	50	200
ESCT-RC100	1000A	0.5	100	395
ESCT-RC150	5000A	0.5	150	525

For additional details on Rogowski coils, check our website.

### 2.5.2 Rogowski Coil Wiring Diagram

Wiring Reference		
Coil cable	Meter Terminal	Screw Torque
Blue Wire(+)	S1	0.4Nm
Black Wire(-)	S2	0.4Nm

### 2.5.3 Rogowski Coil Setting





The primary current ranges from 0A to 10000A with 3 selectable scales. The CT1 setting depends on the current input of Rogowski coils.

Range of current input(A)	CT1 setting(kA)
$0 < I \leq 500$	0.5
$500 < I \leq 1000$	1
$1000 < I \leq 5000$	5
$5000 < I \leq 10000$	10

## Chapter 3. Operation



### 3.1 Button Functions

The buttons operate as follows:

Button	Short click		Long press (3s)	
	Display mode	Setup mode	Display mode	Setup mode
	V1 V2 V3 V1-2 V2-3 V3-1 I1 I2 I3 IN V %THD I %THD	Return to previous menu		
	Hz PF PF1 PF2 PF3 MD of I1 I2 I3 MD of Power	Previous page or increase value	CRC	
	P1 P2 P3 Q1 Q2 Q3 S1 S2 S3 P-t Q-t S-t	Next page or decrease value		
	Active E-t Reactive E-t Imp Active E Exp Active E Imp Reactive E Exp Reactive E	Move to right side	Enter Setup mode	Confirm setting

### 3.2 Installation Display

Connect the wire and power on the meter to enter the normal measurement state. The screen display is as follows:

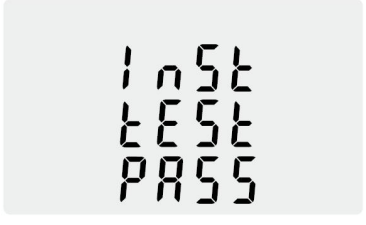

	<p>The first screen lights up all display segments and can be used as a display check.</p>
	<p>The second screen and the third screen indicates the firmware installed in the unit. Note: the actual display might be different with the left on here.</p>



	
	<p>The interface performs a self-test and indicates the result if the test passes.</p>

### 3.3 Basic information display

#### 3.3.1 Voltage and current

Each successive pressing of the  button selects a new range:

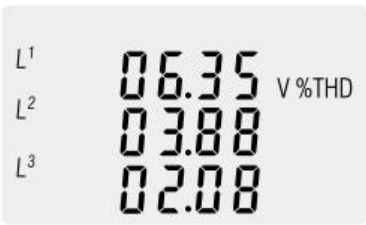
	<p>Phase to neutral voltage (Not available under 3P3W)</p>
	<p>Phase to phase voltage (Not available under 1P2W)</p>
	<p>Current of each phase</p>

	<p>Neutral current (Not available under 3P3W&amp;1P2W )</p>
	<p>Phase to neutral voltage THD% (Phase to phase voltage THD% under 3P3W)</p>
	<p>Phase current THD%</p>

### 3.3.2 Frequency, Power factor and Demand

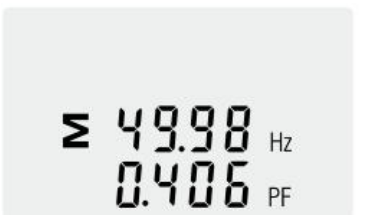
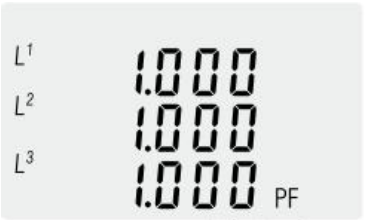

Each successive pressing of the  button selects a new range:

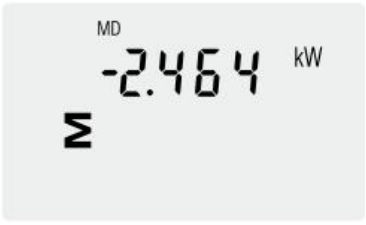
	<p>Frequency and Power Factor (total)</p>
	<p>Power Factor of each phase (Not available under 3P3W &amp;1P2W)</p>

	<p>Maximum current demand of each phase</p>
	<p>Maximum total power demand</p>



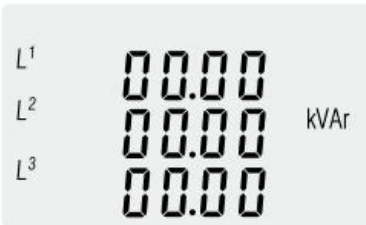

### 3.3.3 Power

Each successive pressing of the  button select a new range:

	<p>Instantaneous Active Power in kW (Not available under 3P3W &amp;1P2W)</p>
	<p>Instantaneous Reactive Power in kVAr (Not available under 3P3W &amp;1P2W)</p>
	<p>Instantaneous Volt-amps in kVA (Not available under 3P3W &amp;1P2W)</p>
	<p>Total kW, kVAr, kVA</p>

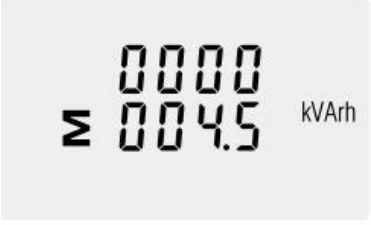
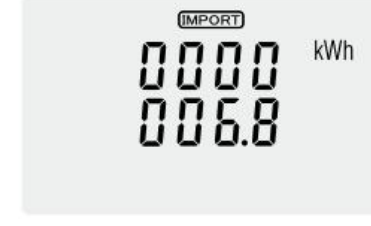
### 3.3.4 Energy

Each successive pressing of the  button shows following measurements:

	Total active energy in kWh
	Total reactive energy in kVArh
	Imported active energy in kWh
	Exported active energy in kWh
	Imported reactive energy in kVArh
	Exported reactive energy in kVArh

### 3.4 Auxiliary information display

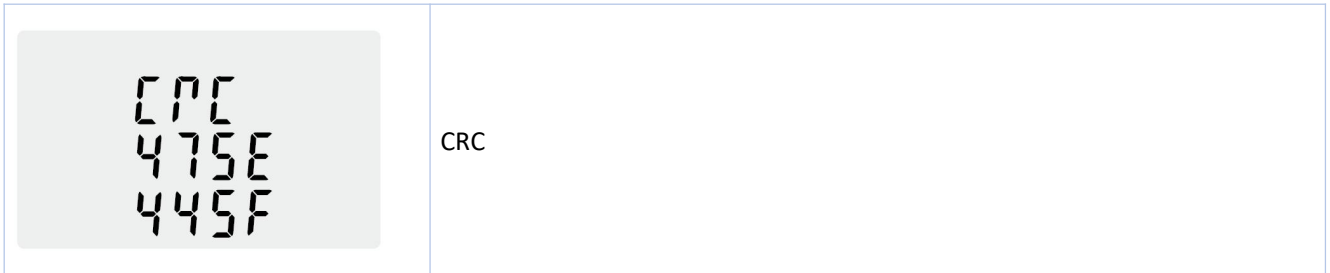

Each successive Long pressing of the  button enter the auxiliary:



### 3.5 Setup Mode

The meter's settable parameters are password protected. Each successive Long pressing on the  button to enter setup mode. Some menu items, such as password and CT, require a four-digit number entry while others, such as supply system, require selection from a number of menu options.

#### 3.5.1 Menu Option Selection

1. Use the  and  buttons to scroll through the different options of the set up menu.

2. Long press  to confirm your selection.

3. If an item flashes, then it can be adjusted by the  and  buttons.

4. Having selected an option from the current layer, long press  to confirm your selection.

5. Having completed a parameter setting, press  to return to a higher menu level.



You will be able to use the  and  buttons for further menu selection.

6. On completion of all setting-up, press  repeatedly until the measurement screen is restored.

#### 3.5.2 Number Entry Procedure

When setting up the unit, some screens require the entering of a number. In particular, on entry to the setting up section, a password must be entered. Digits are set individually, from left to right.











The procedure is as follows:



1. The current digit to be set flashes and is set using the  and  buttons.

2. Short press  to confirm the digit setting and remove to the next.

3. After setting the last digit, long press  to confirm the setting.

4. Press  to return to a higher menu level.

page	Settings interface	Set status	Optional configuration
1			<b>Password</b> Default: 1000
2			<b>Modbus address setting</b> Range: 001~247 Default: 001
3			<b>Baudrate setting</b> Option: 2.4k, 4.8k, 9.6k, 19.2k, 38.4k bps Default: 9.6k bps
4			<b>Parity bit setting</b> Option: NoNE, EVEN, Odd Default: NoNE
5			<b>Stop bit setting</b> Option: 1, 2 Default: 1
6			<b>CT2</b> --Fixed at 85mV

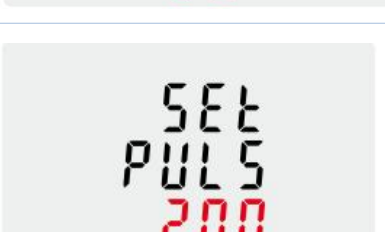
7			<b>CT1 setting</b> Option: 0.5, 1, 5, 10 kA Default: 1 kA
8			<b>PT2 setting</b> Rang: 100~500V Default: 400V
9			<b>PT1 setting</b> Range: 0400~9999V Default: 400V
10			<b>Pulse output setting</b> Option: kWh, kVArh (imported, exported, total) Default: total kVArh
11			<b>Pulse rate setting</b> Option: 0.001, 0.01, 0.1, 1, 10, 100, 1000 kWh/kVArh per imp Default: 0.01 kVArh per imp
12			<b>Pulse duration setting</b> Option: 200, 100, 60 mS Default: 200mS
13			<b>Demand interval time setting</b> Option: 0, 5, 8, 10, 15, 20, 30, 60min Default: 60min

14			<p><b>Backlit time setting</b>  Option: ON, OFF, 1, 5, 10, 30, 60, 120 min  Default: ON</p>
15			<p><b>System type setting</b>  Option: 3P4W, 3P3W, 1P3W, 1P2W  Default: 3P4W</p>
16			<p><b>CLR</b>  Option: Max.Demand, resettable energy</p>
17			<p><b>Password setting</b>  Range: 0000~9999  Default: 1000</p>
18			<p><b>IA current direction setting</b>  Option: Frd, Rev  Default: Frd</p> <p>*Frd = Forward; Rev = Reverse  *And so on for IB &amp; IC operation.</p>

IF you have any question, please feel free to contact our sales team.

**Zhejiang Eastron Electronic Co., Ltd.**

No.52, DongJin Rd. Jiaxing, Zhejiang, 314001, China

Tel: 400-996-9296 Fax: +86-573-83698883

Email: sales@eastrongroup.com

[www.eastrongroup.com](http://www.eastrongroup.com)

