

## Rogowski Coils-ESCT-RC series

### Ø8 mm flexible Rogowski coil Fixed

- High linearity from 1A to 100kA
- Wide dynamic range
- Very useful with large size or awkward shaped conductors or in places with limited access
- Not damaged by large overloads
- Non-intrusive, no power drawn from the main
- Measurement uniformity at any position of the conductor inside the coil
- Excellent degree of rejection to the external current conductor
- Thanks to its light weight, it can be changed on the measured conductor
- Totally shielded

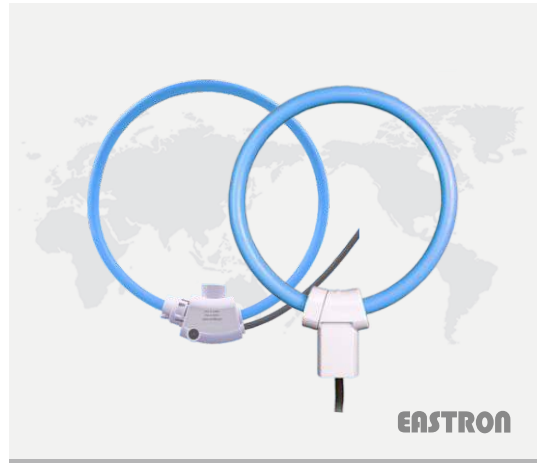

## Description

ESCT-RC series are flexible current transducers based on Rogowski principle, particularly suitable for measurement in combination with portable devices. ESCT-RC coils are available in different sizes and can be supplied according to customer's design, therefore they can be used in all those applications, in which traditional transducers are not fitting due to its size and/or weight. Due to its specific features, flexible Rogowski coil is an extremely comfortable solution for current measurement and can be used in a number of cases where traditional current transducer is not the adequate solution. ESCT-RC series provided with a shield against the influence of external magnetic fields, therefore it grants a stable measurement from low currents to hundreds of kA. The Rogowski coils must be connected to an electronic integrator for 90° phase shift compensation and frequency equalization. Our portable and panel meters can interface Rogowski coils directly without the need of the external integrators. This is an advantage because there is no external boxes or any power supply with consequent ease of use. The particular features of the Rogowski coils combined with the extremely flexible input programming of our portable meters, allow to carry out measurement by all applications.

## Feature

- Very thin coil diameter: down to 8 mm
- Calibrated to 0.5%
- Measurement uniformity at any position of the conductor inside the coil
- Excellent degree of rejection to the external current conductor
- Delivered already calibrated

## Applications

- Measuring devices, lab instrumentation
- Power monitoring & control systems
- DC ripple measurement
- Harmonics and transients monitoring
- Power meter, Power analyzer sensor

## Related Products

- Integrator S9, D1, TP, DTP, ATP

## Benefits

- Due to its structure, flexible Rogowski coils allow to embrace conductors or grouped cables, which are large and difficult to reach, without any hazard.
- The coil output gives a low voltage signal, therefore there is no danger from open-circuited secondary. This makes Rogowski transducers extremely suitable for temporary measurements, for example in combination with portable analysers.
- Unlike traditional current transformer with magnetic core, the Rogowski coil is a non-intrusive transducer. Since it has no hard core, it draws no power from the main circuit carrying the current to be measured.

## What is a Rogowski Coil

Rogowski coils have been used for the detection and measurement of electric currents for decades. They are based on a simple principle : an “ air-cored ” coil is placed around the conductor in a toroidal fashion and the magnetic field produced by the current induces a voltage in the coil . The voltage output is proportional to the rate of change of current. This voltage is integrated , thus producing an output proportional to the current. By using precision winding techniques, especially developed for the purpose, the coils are manufactured so that their output is not influenced by the position of the conductor within the toroid , and to reject interference from external magnetic fields caused , for example , from nearby conductors . Basically , a Rogowski coil current measuring system consists of a combination of a coil and conditioning electronics. Rogowski coil current transducers are used for the AC measurement . They can be used in similar circumstances to current transformers but for many applications they have considerable advantages:

- Wide dynamic range.
- High linearity.
- Very useful with large size or awkward shaped conductors or in places with limited access. Thanks to the structure without hard core , the coil can be easily manufactured according to the application or to the available space.
- Unlike traditional current transducers, there is no danger from open-circuited secondaries.
- They cannot be damaged by large overloads.
- They are non-intrusive. They draw no power from the main circuit carrying the current to be measured.
- They are also light weighted and in some applications are light enough to be suspended on the conductor being measured.

The transducer does not measure direct currents but, unlike a current transformer, it can carry out accurate measurements of AC component even if there is a large superimposed DC component, since there is no iron core causing saturation. This feature is particularly useful for measuring ripple currents for example in battery charging systems.

## Specifications

### Transducer

Coil length:	from 20cm to 1000cm
Coil diameter:	8.3 ±0.2 mm
Fastening:	bayonet holder
Weight:	150g
Material:	thermoplastic UL94-V0

### Electrical Characteristics:

Output level (RMS):	50mV / KA @50Hz    80mV / KA @50Hz 85mV / KA@50Hz    100 mV / KA @50Hz
Coil resistance:	from 70 to 900 Ω
Positioning error:	better than ±1% of reading (with 15 mm diameter cable)
Frequency range:	approx 40 Hz to 20 kHz
Working voltage:	1000 V <sub>RMS</sub> CAT III 600 V <sub>RMS</sub> CAT IV pollution degree 2
Test voltage:	7400 V <sub>RMS</sub> / 1 min

### Connection Cable

Type:	2 x 0.15 mm + shield
Length:	on request

### Environmental Conditions

Operating temperature:	from -30°C to +80°C
Storage temperature:	from -40°C to +80°C
Protection degree:	IP67

### Standards Compliance

Safety:	EN61010-1, EN61010-031, EN61010-2-031, EN61010-2-032
---------	---

Other requirements, please contact us to OEM.

## Model Table

Coil code	Reference Rated Current	Class	Window Size (mm)		Coil Length (mm)	Type No.	Remark
			A	B			
ESCT-RC60	500A	0.5	60	50	200	A	1. Different coil color Black, Yellow, Red, Green, Blue ( MOQ required) 2. Other cable length longer than standard (2m), up to 15m 3. Other coil length than these listed, up to 1000cm. 4. Product code: ESCT-RC-xxx (window zise)
ESCT-RC100	1000A	0.5	135	100	395	B	
ESCT-RC105	1500A	0.5	105	100	350	A	
ESCT-RC150	3000A	0.5	165	150	525	B	
ESCT-RC200	6000A	0.5	240	200	665	B	
ESCT-RC240	10000A	0.5	245	240	800	A	
ESCT-RC16	100A	0.5	22	16	80	C	
ESCT-RC24	300A	0.5	27.5	24	97	C	
ESCT-RC36	600A	0.5	36	37	130	C	

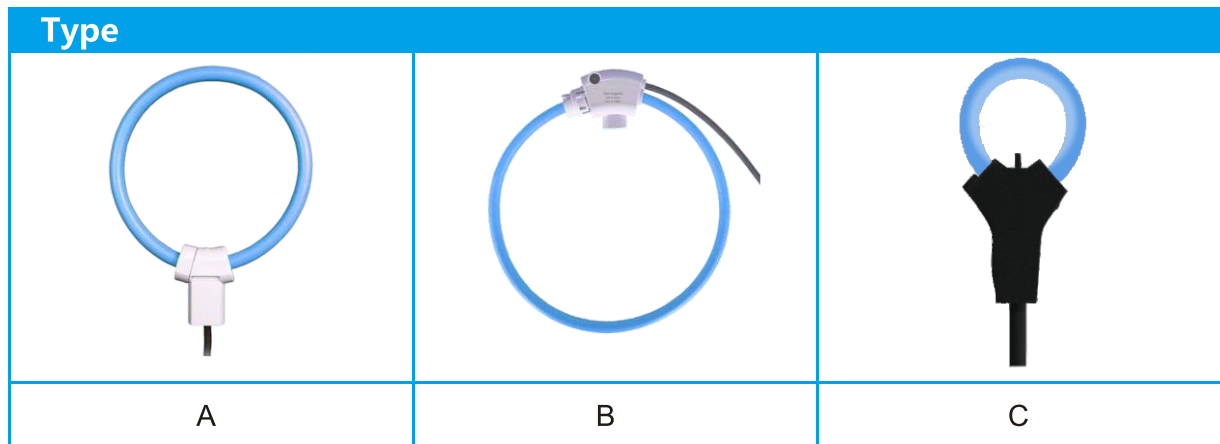

Final Code=Coil model ( ESCT-RC)+Window size +Coil length+Type+Coil color+Signal cable length+Output ratio tolerance  
 For example: ESCT - RC60 - 200 - A - Y - 2m --100 ( window size 60mm, coil length 200mm, A type, yellow coil, signal cable length 2meter output 100mV/kA@50Hz 0.5% tolerance)

## How to use

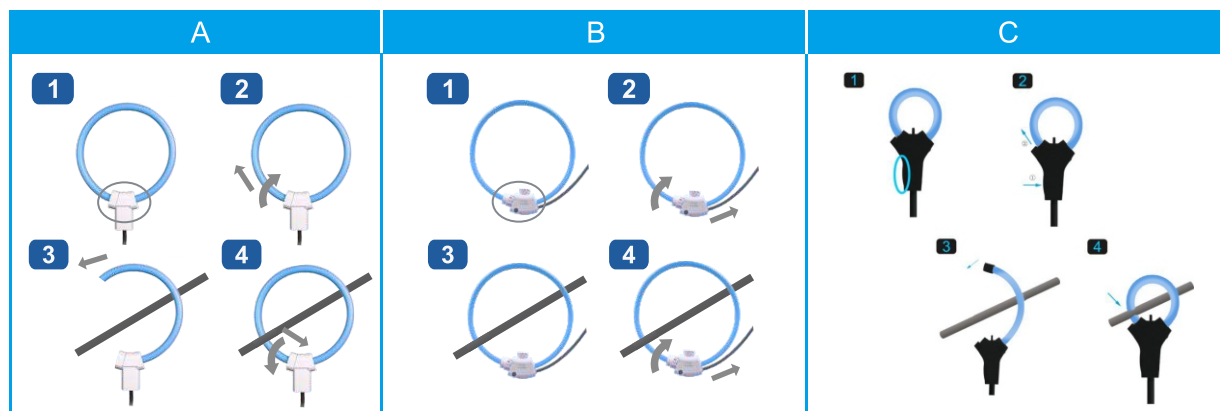

## Position sensitivity

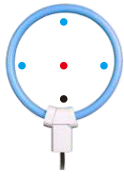

### Conductor Position

### Typical Error (%)

- Adjacent to the clip together mechanism < 0.5%
- Adjacent to the inside coil edge < 0.8%
- Adjacent to the opposite clip < 1%



### Conductor Position

### Typical Error (%)

- Adjacent to the clip together mechanism < 0.5%
- Adjacent to the inside coil edge < 0.8%
- Adjacent to the opposite clip < 1%



### Conductor Position

### Typical Error (%)

- Adjacent to the clip together mechanism < 0.5%
- Adjacent to the inside coil edge < 0.8%
- Adjacent to the opposite clip < 1%

## Dimensions

Dimensions tolerance

A,B,C,F:  $\pm 5\text{mm}$ , D:  $\pm 0.2\text{mm}$ , E:  $\pm 10\text{mm}$

Type A:	RC60	RC105	RC240
A.Windows Size A	60	105	245
B.Windows Size B	50	100	240
C.Coil O.D.	66	121	261
D.Coil Section	8		
E.Lead Cable Total Length	2000		
F.Coil Length	200	350	800
Ratio (Calibrated)	80mV/KA@50Hz; 85mV/KA@50Hz; 100mV/KA@50Hz		

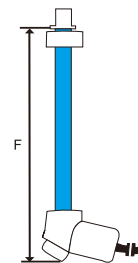
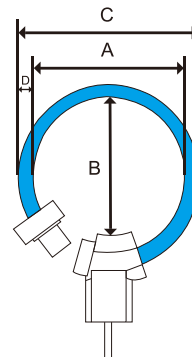
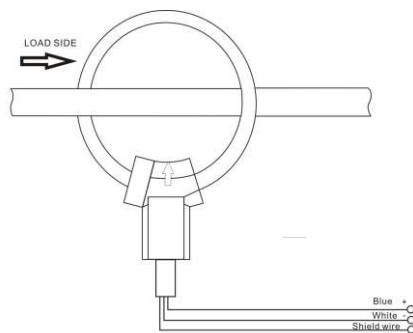
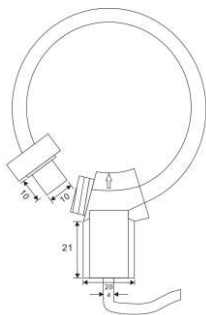

Type B :	RC100	RC150	RC200
A.Windows Size A	135	165	210
B.Windows Size B	100	150	200
C.Coil O.D.	151	181	226
D.Coil Section	8		
E.Lead Cable Total Length	2000		
F.Coil Length	395	525	665
Ratio (Calibrated)	80mV/KA@50Hz;85mV/KA@50Hz;100mV/KA@50Hz		

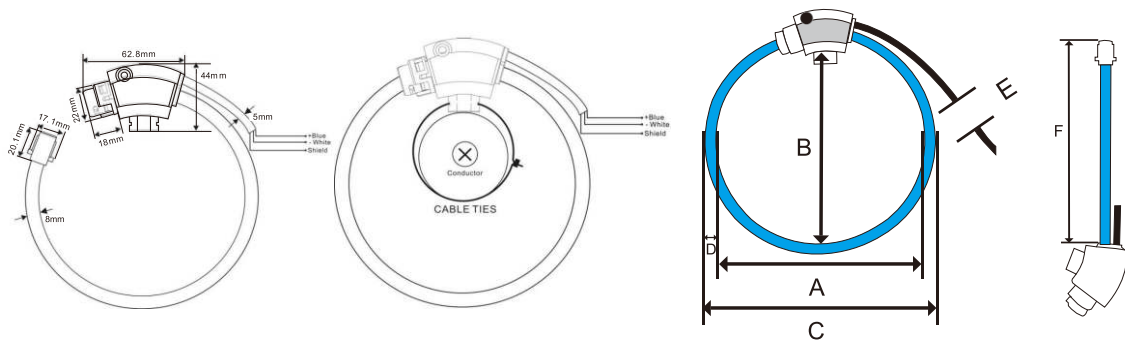

Type C:	RC16	RC24	RC36
A.Windows Size A	22	27.5	36
B.Windows Size B	16	24	37
C.Coil O.D.	34	39.5	48
D.Coil Section	6		
E.Lead Cable Total Length	2000		
F.Coil Length	80	97	130
Ratio (Calibrated)	50mV/KA@50Hz		

